

ශ්‍රී ලංකා විභාග දෙපාර්තමේන්තුව ශ්‍රී ලංකා විභාග දෙපාර්තමේන්තුව ශ්‍රී ලංකා විභාග දෙපාර්තමේන්තුව ශ්‍රී ලංකා විභාග දෙපාර්තමේන්තුව ශ්‍රී ලංකා විභාග දෙපාර්තමේන්තුව
 இலங்கைப் பரீட்சைத் திணைக்களம் இலங்கைப் பரීட்சைத் திணைக்களம் இலங்கைப் பரීட்சைத் திணைக்களம் இலங்கைப் பரීட்சைத் திணைக்களம் இலங்கைப் பரීட்சைத் திணைக்களம்
 Department of Examinations, Sri Lanka Department of Examinations, Sri Lanka Department of Examinations, Sri Lanka Department of Examinations, Sri Lanka Department of Examinations, Sri Lanka
 இலங்கைப் பரීட்சைத் திணைக்களம் இலங்கைப் பரීட்சைத் திணைக்களம் இலங்கைப் பரīட்சைத் திணைக்களம் இலங்கைப் பரīட்சைத் திணைக்களம் இலங்கைப் பரīட்சைத் திணைக்களம்
 Department of Examinations, Sri Lanka Department of Examinations, Sri Lanka Department of Examinations, Sri Lanka Department of Examinations, Sri Lanka Department of Examinations, Sri Lanka

34 E I

අධ්‍යයන පොදු සහතික පත්‍ර (සාමාන්‍ය පෙළ) විභාගය, 2020
 கல்விப் பொதுத் தராதரப் பத்திர (சாதாரண தர)ப் பரீட்சை, 2020
 General Certificate of Education (Ord. Level) Examination, 2020

විද්‍යාව I
 விஞ்ஞானம் I
 Science I

පැය එකයි
 ஒரு மணித்தியாலம்
 One hour

Note :

- * Answer all questions.
- * In each of the questions 1 to 40, pick one of the alternatives (1), (2), (3), (4) which you consider is correct or most appropriate.
- * Mark a cross (X) on the number corresponding to your choice in the answer sheet provided.
- * Further instructions are given on the back of the answer sheet. Follow them carefully.

1. The fundamental structural and functional unit of life is the
 (1) cell. (2) tissue. (3) organ. (4) system.
2. What is the pair of subatomic particles which attract each other?
 (1) electrons and neutrons (2) electrons and protons
 (3) protons and neutrons (4) electrons and electrons
3. The unit of momentum is
 (1) kg m s^{-1} . (2) kg m s^{-2} . (3) $\text{kg m}^{-1} \text{s}^{-1}$. (4) $\text{kg m}^2 \text{s}^{-2}$.
4. The figures A, B and C below indicate three types of muscle tissues.



A

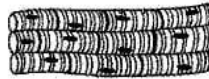

B



C

A, B and C above respectively are

- (1) smooth muscle, cardiac muscle and skeletal muscle tissues.
 - (2) skeletal muscle, smooth muscle and cardiac muscle tissues.
 - (3) smooth muscle, skeletal muscle and cardiac muscle tissues.
 - (4) cardiac muscle, skeletal muscle and smooth muscle tissues.
5. Which of the following is the molecule with highest number of covalent bonds?
 (1) O_2 (2) N_2 (3) NH_3 (4) CO_2
 6. Heat is transmitted from the Sun to the Earth by
 (1) radiation. (2) conduction.
 (3) convection. (4) radiation and convection.
 7. As was extracted by a student from an environmental pyramid, that ecosystem has one producer, eight primary consumers and twenty three secondary consumers. The student has extracted this information from a
 (1) upright number pyramid. (2) inverted number pyramid.
 (3) upright biomass pyramid. (4) inverted biomass pyramid.
 8. Here is shown the displacement-time graph of the motion of an object. During the time intervals from 0 to t_1 and t_1 to t_2 , the nature of the motion of the object respectively is,
 (1) a uniform velocity and an acceleration.
 (2) a uniform velocity and a retardation.
 (3) a uniform acceleration and a retardation.
 (4) a uniform retardation and an acceleration.

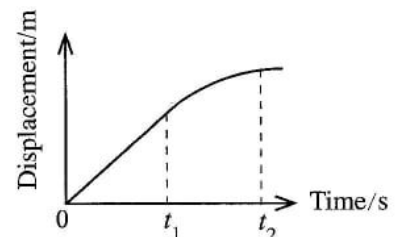

- Questions 9 and 10 are based on the following information and the illustration. Production of haemoglobin is disturbed by thalassemia, an inherited disease caused by the gene mutation in a somatic chromosome. With regard to the production of haemoglobin naturally, the dominant gene is T while the mutant recessive gene is t. A, B, C, and D indicate the F₁ generation.

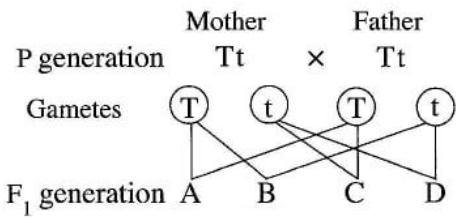

9. A thalassemia patient belonging to the F₁ generation is
 (1) A. (2) B. (3) C. (4) D.
10. The ratio among the thalassemia patients, healthy disease carriers and healthy individuals belonging to the F₁ generation is
 (1) 1 : 1 : 1. (2) 1 : 1 : 2. (3) 1 : 2 : 1. (4) 2 : 1 : 1.
11. Which statement is always true about the magnitude of displacement of a certain object?
 (1) greater than the distance moved (2) equal to the distance moved
 (3) lesser than the distance moved (4) either equal to or less than the distance moved
12. The electronic configurations of the atoms of two elements X and Y are 2, 8, 1 and 2, 8, 7 respectively. Of the following statements about the pair of those elements, which statement is **false**?
 (1) located in the same period in the Periodic Table
 (2) located in the same group in the Periodic Table
 (3) chemically combine forming ionic bonds
 (4) combine and form the compound with the chemical formula XY
13. What is the number of O₂ molecules contained in 64 g of oxygen gas? (O = 16)
 (1) 6.022×10^{23} (2) $2 \times 6.022 \times 10^{23}$ (3) $4 \times 6.022 \times 10^{23}$ (4) $64 \times 6.022 \times 10^{23}$
14. W, X, Y and Z are four elements consecutively placed in the Periodic Table with atomic numbers below 20. The graph indicates how their first ionisation energy (I₁) varies against the atomic number. In which group of the Periodic Table is Y placed?
 (1) I (2) II
 (3) III (4) IV

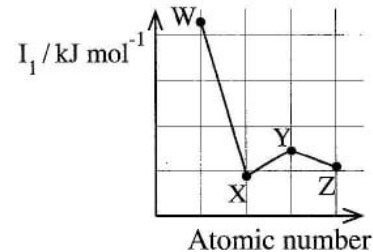

15. The substances acting as the main components providing energy for the functioning of the human body are
 (1) proteins and lipids. (2) proteins and vitamins.
 (3) carbohydrates and lipids. (4) carbohydrates and proteins.
16. A person's glucose level in the blood has increased above the optimum level. Which of the following food items should he consume minimally?
 (1) meat (2) milk (3) green gram (mung/payaru) (4) bread
17. Select the **false** statement about nucleic acids.
 (1) building unit is called nucleotide (2) a natural polymer
 (3) store hereditary information (4) contain the elements C, H, O and N only
18. Examples for the seeds/fruits dispersed by water, wind and explosive mechanism respectively are
 (1) Ceylon almond(kottamba/kaththappu), hora and mango. (2) lotus, castor (endaru/amanakku) and rubber.
 (3) coconut, milkweed (vara/erukkalai) and rubber. (4) jack, cotton and okra (bandakka/vendi).
19. Which of the following **does not** pass into the foetus from the mother through the umbilical cord?
 (1) blood (2) nutrients (3) oxygen (4) pathogens
20. What is the ray diagram which illustrates the phenomenon of total internal reflection?

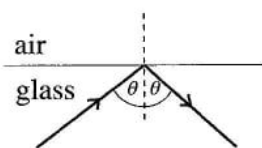

(1)

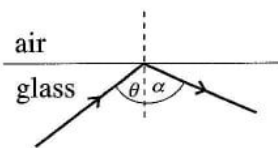

(2)

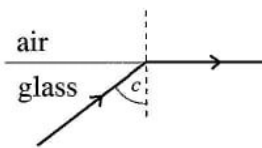

(3)

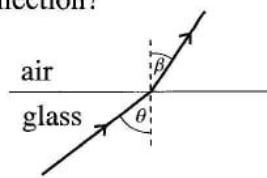

(4)

21. An athlete finishing a running event suffered from a cramp in his leg. What is the chemical compound which is produced in muscle cells causing the cramp?
 (1) carbon dioxide (2) ethyl alcohol (3) lactic acid (4) acetic acid
22. A warm-blooded (homoeothermic) animal and a cold-blood (poikilothermic) animal respectively are
 (1) pigeon and frog. (2) bear and rat. (3) rat snake and whale. (4) crocodile and tortoise.
23. Which arrangement can be used to obtain a voltage of 3 V from two dry cells each with an electromotive force of 1.5 V?

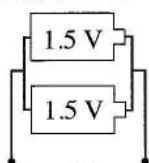

(1)

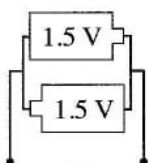

(2)

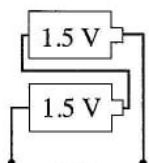

(3)

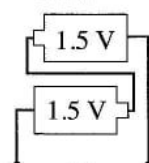

(4)

24. What is the metal that reacts with hot water but not with cold water?
 (1) sodium (2) magnesium (3) aluminium (4) calcium
25. What is the correct statement about the Covid-19 virus?
 (1) can be observed by the optical microscope (2) carries out metabolic activities
 (3) bears a nucleus with DNA (4) shows living as well as non-living characteristics
26. When salt is extracted from sea water in a saltern, what is the compound that precipitates along with NaCl?
 (1) Na_2SO_4 (2) MgCl_2 (3) CaCO_3 (4) CaSO_4
27. The maximum upthrust exerted by water on a certain object is less than the weight of the object. Then, the object will
 (1) float on the water surface. (2) float partly immersed in water.
 (3) float fully immersed in water. (4) sink fully in water.
28. What is the part common to the human digestive system and the human respiratory system?
 (1) mouth (2) oesophagus (3) pharynx (4) larynx
29. The figure shows how a couple of forces is applied to rotate a wheel of 0.4 m radius. How much is the moment of this couple?
 (1) $5 \times 0.4 \text{ Nm}$ (2) $5 \times 0.8 \text{ Nm}$
 (3) $5 \times 5 \times 0.4 \text{ Nm}$ (4) $5 \times 5 \times 0.8 \text{ Nm}$

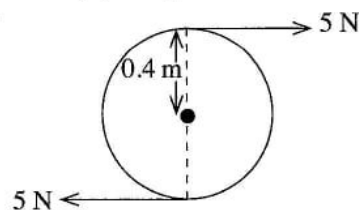

30. What is the mole fraction of O_2 in a mixture containing 96 g of oxygen gas (O_2) and 56 g of nitrogen gas (N_2)? ($N = 14, O = 16$)
 (1) $\frac{1}{5}$ (2) $\frac{2}{5}$ (3) $\frac{3}{5}$ (4) $\frac{4}{5}$
31. Given below are four ways by which zinc metal and hydrochloric acid were reacted at room temperature. In which way is hydrogen gas liberated with the highest speed?
 (1) zinc granules + dilute hydrochloric (2) zinc granules + concentrated hydrochloric
 (3) zinc powder + dilute hydrochloric (4) zinc powder + concentrated hydrochloric
32. Between a strong acid and a strong base,
 (1) an exothermic neutralization reaction occurs. (2) an endothermic neutralization reaction occurs.
 (3) an exothermic combination reaction occurs. (4) an endothermic combination reaction occurs.
33. A conductor carrying an electric current I , is kept perpendicular to a magnetic field as shown in the diagram. Horizontal lines indicate the direction of the magnetic field. The direction of the force acting on the conductor is
 (1) toward the left on the plane of the paper.
 (2) toward the right on the plane of the paper.
 (3) into the plane of the paper perpendicular to the plane.
 (4) out of the plane of the paper perpendicular to the plane.

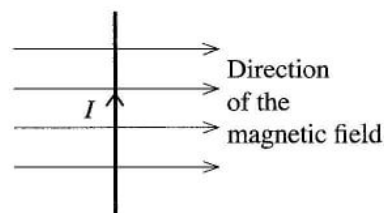

34. Under normal atmospheric pressure, a pure block of ice at temperature -10°C was heated at a uniform rate until it was turned into liquid water and then for some time after the water started to boil. Which graph correctly indicates the variation of the temperature of the system with time?

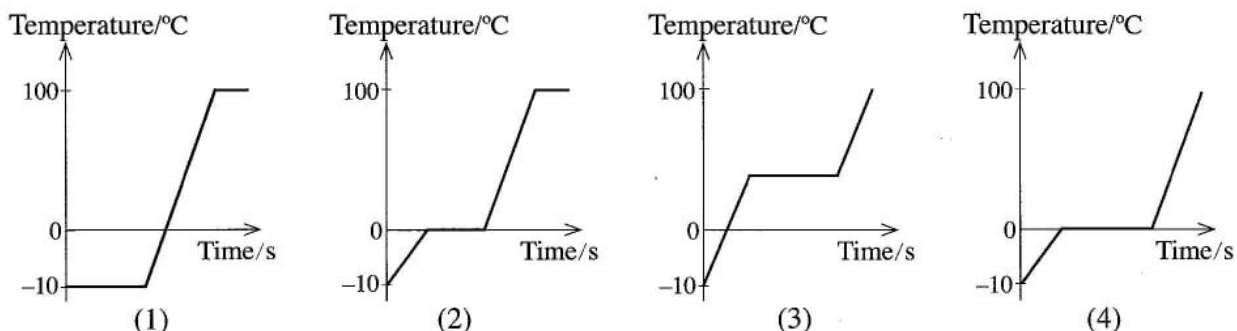

35. Consider the following statements presented regarding natural rubber.

A - It is a linear polymer. B - Isoprene is the monomer. C - There are cross links among the chains.

Of these statements

- (1) only A is true. (2) only A and B are true.
 (3) only B and C are true. (4) only A and C are true.
36. Corrosion of iron can be controlled by keeping iron in contact with the bivalent metal M. What is the half reaction to which the metal M is subjected here?
- (1) $\text{M(s)} \longrightarrow \text{M}^{2+}(\text{aq}) + 2\text{e}$ (2) $\text{M}^{2+}(\text{aq}) \longrightarrow \text{M(s)} + 2\text{e}$
 (3) $\text{M}^{2+}(\text{aq}) + 2\text{e} \longrightarrow \text{M(s)}$ (4) $\text{M(s)} \longrightarrow \text{M}^+(\text{aq}) + \text{e}$

37. A 4 N force and a 3 N force are applied on an object at the same instance. Consider the following statements given about the magnitude of the resultant obtainable at that occasion.

A - The maximum magnitude of the resultant obtainable is 7 N.

B - The minimum magnitude of the resultant obtainable is 1 N.

C - The magnitude of the resultant obtainable is always 5 N.

Of the above, the correct statement(s) is / are

- (1) only A. (2) only B. (3) only C. (4) only A and B.
38. A strong bar magnet is moved into and away from an insulated wire coil with a large number of turns as illustrated by the diagram. What is the correct observation about the instances of movement of the magnet?

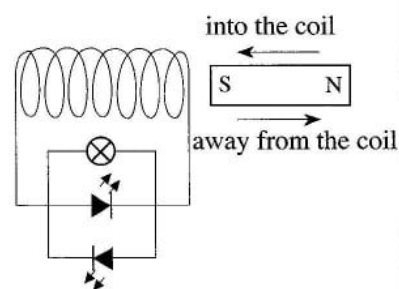

- (1) In both instances, both the bulb and two LEDs light simultaneously.

- (2) In both instances, the bulb lights and only one LED lights.
 (3) The bulb and one LED light only when moved into the coil.
 (4) The bulb and one LED light only when moved away from the coil.

39. Consider the following statements.

A - Biomagnification occurs along a food chain.

B - Toxic chemical pollutants concentrate more in the upper trophic levels of a food chain.

Of the above statements,

- (1) both A and B are true. (2) A is true while B is false.
 (3) A is false while B is true. (4) both A and B are false.
40. A statement displayed on a board near a tank is shown in the figure. Which of the following human activities in connection with the tank would have contributed most to the change mentioned on the board?

"It is you who turned the water in this tank green"

- (1) clearing the area above the tank
 (2) increase in algae population due to fishing
 (3) accumulation of oil and grease due to vehicle wash
 (4) addition of faecal and excretory matter to the water

Part B

- Answer only **three** questions from the questions No. 5, 6, 7, 8 and 9.

5. (A) Given below is a sketch of a part of the human digestive system.

- (i) Name the parts labelled P, Q and R.
- (ii) Describe briefly how food is subjected to mechanical digestion in P.
- (iii) A secretion essential for the emulsification of lipids contained in food is produced by Q. Name that secretion.
- (iv) (a) What is the enzyme which is secreted by R and contributes to digest lipids?
(b) State the **two** products formed by the action of that enzyme on lipids.
- (v) The pair of hormones insulin and glucagon produced by R contributes to regulate the internal environment of the body.
(a) What is the factor that is regulated in the internal environment of the body by the action of those hormones?
(b) Explain briefly how those hormones contribute to regulate the factor you stated in (a) above.

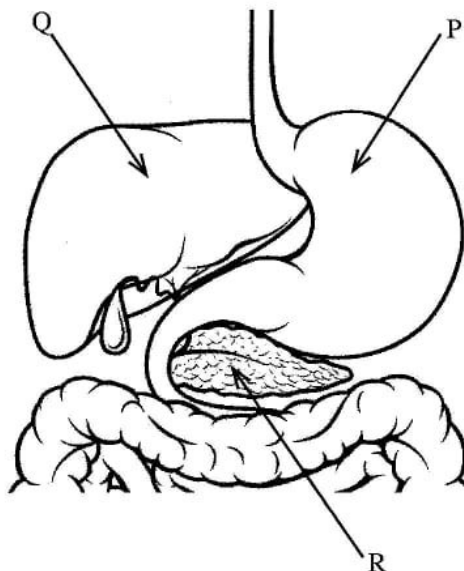

(B) Kidneys are considered the main organs which perform nitrogenous excretion in humans.

- (i) What is excretion?
- (ii) Name a nitrogenous excretory product removed by kidneys.
- (iii) What is the structural and functional unit of the kidneys?
- (iv) One step in the process of forming urine in the structural and functional unit of the kidneys is known as **secretion**.
(a) Describe briefly how secretion occurs.
(b) State the other **two** steps in the formation of urine.

(20 marks)

6. (A) A longitudinal section of a fractionating tower used for refining crude oil is given below. Contained in abundance are the compound X in the fraction released from the outlet ①, compound Y in the fraction released from the outlet ④ and the compound Z in the fraction released from the outlet ⑥.

- (i) By what common name is the group of organic compounds contained in abundance in crude oil known?
- (ii) Name the crude oil refining technique employed in the tower.
- (iii) The boiling points of the compounds X, Y and Z are T_X , T_Y and T_Z respectively. Write them in the ascending order.
- (iv) X is a compound with a single carbon atom and containing carbon and hydrogen only. Draw the dot and cross diagram of a X molecule.
- (v) Write the balanced chemical equation relevant to the complete combustion of one mole of compound X in oxygen gas.
- (vi) The substance released from outlet ⑦ of the tower is used to construct roads. Name that substance.
- (vii) State an environmental problem caused by the gaseous components that would be released to the environment during refining of crude oil.

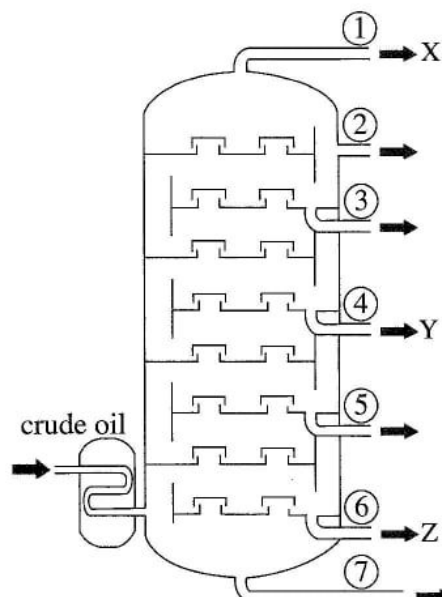

(B) A is a strong acid and B is a strong base. Two products are produced in the reaction between A and B. One of those products is sodium chloride (NaCl).

- (i) Write the chemical formulae of the compounds A and B.
- (ii) Name the compound that is produced as the other product during the reaction between A and B.
- (iii) Describe briefly how the compound you stated in (ii) above is formed during the reaction between A and B.

(iv) An apparatus set up to determine the heat change associated with the reaction between A and B is shown in the diagram.

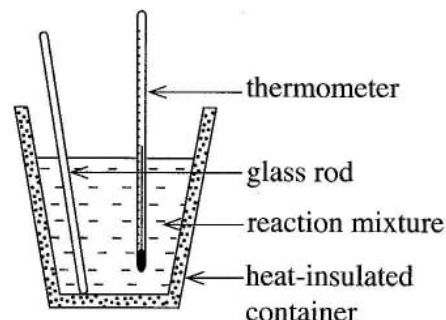

(a) In the apparatus, what measure has been taken to reduce the heat loss?

(b) Suggest a course of action which can be taken to reduce further the heat loss in this apparatus.

(v) 50 cm³ each of A acid solution and B base solution of equal concentration were taken and mixed in the above apparatus. The temperature change occurred here was determined to be 10 °C.

(a) What are the readings that should be taken to determine the above temperature change?

(b) Calculate the heat change associated with the above reaction. (The specific heat capacity of the reaction mixture is 5000 J kg⁻¹ °C⁻¹ and its density is 1 g cm⁻³.)

(vi) Sketch an energy level diagram to illustrate the energy change occurring in the chemical reaction between A and B above.

(20 marks)

7. (A) The following activities were done by a student at home using a glass hand lens.

Activity 1 - Reading a label with very small letters

Activity 2 - Burning a piece of dry cotton wool by solar rays

Activity 3 - Obtaining an image of a tree in the compound on a wall in the house

- (i) Name the type of the lens that is used as the hand lens.
- (ii) Between which two points related to the lens should the label be placed in Activity 1?
- (iii) Indicate by a ray diagram how light rays travel through the lens in Activity 2.
- (iv) Instead of the hand lens, what type of a mirror can be used to carry out Activity 2?
- (v) State **two** characteristics of the image formed in Activity 3.
- (vi) Name **two** instruments that are made using lenses of the type used for hand lenses.

(B) When brakes are applied to a normal motor vehicle at run, its kinetic energy is lost due to friction.

- (i) Brakes are applied to a motor vehicle of mass 1000 kg when running at a speed of 20 m s⁻¹.
 - (a) Calculate the kinetic energy of the vehicle at the instance just before applying brakes.
 - (b) Name **two** forms of energy to which the kinetic energy lost gets converted when applying brakes.
- (ii) A part of the kinetic energy lost when applying brakes to an electric motor vehicle is converted to electrical energy and its battery is charged.
 - (a) Name the equipment that converts kinetic energy to electrical energy here.
 - (b) Name and describe briefly the phenomenon of converting lost kinetic energy of the vehicle to electrical energy.
 - (c) Name the equipment that converts the electrical energy supplied by the battery to kinetic energy required to run the vehicle.
 - (d) The electromotive force of a battery used in electric motor vehicles is about 400 V. This is composed of a set of cells where the electromotive force of one cell is 4 V. What is the minimum number of cells required to make this battery?

(20 marks)

8. (A) A student recorded as follows three animals and features of two animals indicated as P and Q as their names were unknown to him found in an okra (bandakka/vendi) cultivation.

- snail
- lizard
- greater coucal (etikukula/chenpakam)
- P - Has a thin, long and vermiform body. The body is divided into equal segments.
- Q - Bears jointed legs and wings.

Write answers to the following questions related to the animals observed.

- (i) (a) Name the two vertebrate animals.
- (b) What is the main characteristic on which the inclusion of those animals in the vertebrate group based?
- (ii) According to the above observations, what is the animal phylum to which P belongs?
- (iii) State another common characteristic specific to the animal species of the phylum to which Q belongs.
- (iv) State a favourable effect and an unfavourable effect which can be expected to have caused by Q on the crop.
- (v) State a primary consumer and a secondary consumer respectively in a food chain that contains animals observed in the okra cultivation.
- (vi) A newspaper has printed greater coucal's scientific name as *Centropus Sinensis*. According to the rules of binomial nomenclature, state **two** errors seen in it.

(B) A cylindrical water tank is kept on the roof of a two storeyed house.

- (i) Consider an occasion in which two identical water taps in the upper floor and the ground floor of the house are kept fully open at the same time.
 - (a) From the tap in which floor does water flow out with higher speed?
 - (b) Give the reason for your answer.
- (ii) The inner cross sectional area of the tank is 1 m^2 and its height is 1 m. (Density of water is 1000 kg m^{-3} and acceleration due to gravity is 10 m s^{-2} .)
 - (a) What is the mass of water in the tank when it is completely filled with water?
 - (b) What is the pressure exerted by water on the bottom of the tank when it is completely filled with water?

(iii) The diagram shows a lever arrangement made to prevent the overflow of water entering the tank. When water gets filled, the buoy lifts closing the valve and the entry of water stops.

- (a) What is the force acting on the buoy at the position shown in the diagram?
- (b) What is the extra force acting on the buoy from the time at which the water level rises and the buoy starts to submerge in water.
- (c) State another advantage gained from this lever arrangement in addition to the prevention of overflow of water.

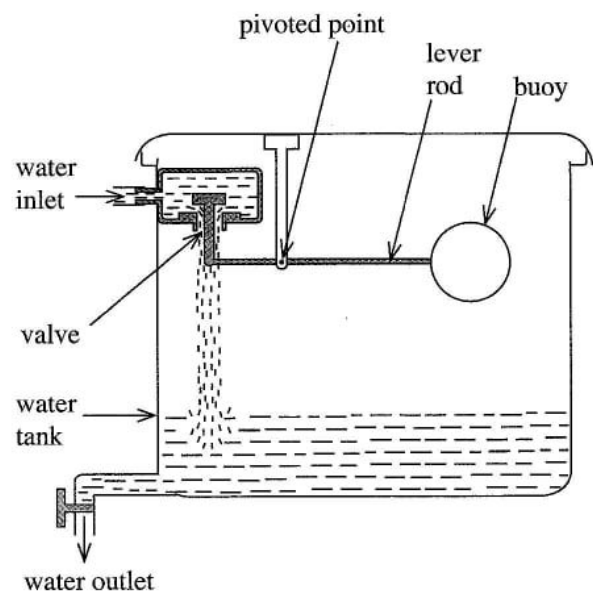

(20 marks)

9. (A) The cell U shown below is an electrochemical cell while the cell W is an electrolytic cell.

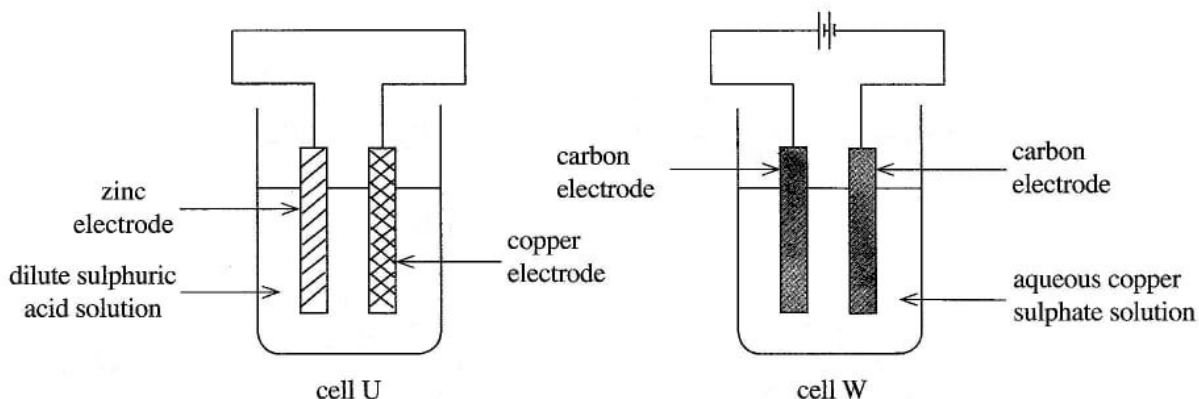

- (i) In which cell above is chemical energy converted to electrical energy?
- (ii) What is the name by which the anode reactions occurring in the two cells are known in common?
- (iii) Indicate the half reaction occurring at the anode of the cell U by a chemical equation.
- (iv) State the convention used to identify the anode and cathode in cell W.
- (v) (a) What change in colour occurs in the electrolytic solution when cell W operates?
 (b) Explain the reason for it.
- (vi) Which electrode is dissolved when the above cells operate?

(B) In order to operate a certain household electronic equipment, the domestic electricity supply has to be converted to a low voltage, direct current electrical supply. For that, an arrangement consisting of the following parts is used:

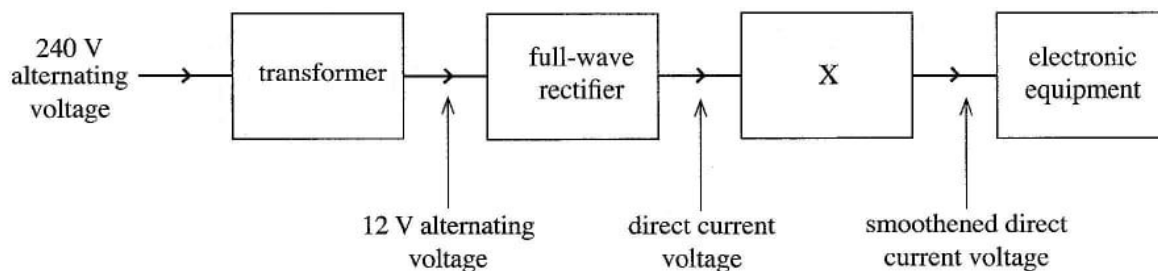

- (i) (a) What type of a transformer is connected to the above arrangement?
 (b) In what coil in this transformer should wires of higher diameter be used? State the reason for it.
- (ii) The number of turns in the primary coil of the above transformer is 1800. What should be the number of turns in the secondary coil?
- (iii) Illustrate graphically how the 12 V alternating voltage supplied by the transformer varies with time.
- (iv) Draw using standard symbols, how the four diodes are connected in the full-wave rectifier circuit.
- (v) Name the device indicated by X.

(20 marks)

ශ්‍රී ලංකා විභාග දෙපාර්තමේන්තුව ශ්‍රී ලංකා විභාග දෙපාර්තමේන්තුව ශ්‍රී ලංකා විභාග දෙපාර්තමේන්තුව ශ්‍රී ලංකා විභාග දෙපාර්තමේන්තුව ශ්‍රී ලංකා විභාග දෙපාර්තමේන්තුව
 இலங்கைப் பரீட்சைத் திணைக்களம் இலங்கைப் பரීட்சைத் திணைக்களம் இலங்கைப் பரීட்சைத் திணைக்களம் இலங்கைப் பரීட்சைத் திணைக்களம் இலங்கைப் பரීட்சைத் திணைக்களம்
 Department of Examinations, Sri Lanka Department of Examinations, Sri Lanka Department of Examinations, Sri Lanka Department of Examinations, Sri Lanka Department of Examinations, Sri Lanka
 இலங்கைப் பரීட்சைத் திணைக்களம் இலங்கைப் பரීட்சைத் திணைக்களம் இலங்கைப் பரීட்சைத் திணைக்களம் இலங்கைப் பரīட்சைத் திணைக்களம் இலங்கைப் பரīட்சைத் திணைக்களம்
 Department of Examinations, Sri Lanka Department of Examinations, Sri Lanka Department of Examinations, Sri Lanka Department of Examinations, Sri Lanka Department of Examinations, Sri Lanka

34 E I

අධ්‍යයන පොදු සහතික පත්‍ර (සාමාන්‍ය පෙළ) විභාගය, 2020
 கல்விப் பொதுத் தராதரப் பத்திர (சாதாரண தர)ப் பரீட்சை, 2020
 General Certificate of Education (Ord. Level) Examination, 2020

විද්‍යාව I
 விஞ்ஞானம் I
 Science I

පැය එකයි
 ஒரு மணித்தியாலம்
 One hour

Note :

- * Answer all questions.
- * In each of the questions 1 to 40, pick one of the alternatives (1), (2), (3), (4) which you consider is correct or most appropriate.
- * Mark a cross (X) on the number corresponding to your choice in the answer sheet provided.
- * Further instructions are given on the back of the answer sheet. Follow them carefully.

1. The fundamental structural and functional unit of life is the
 (1) cell. (2) tissue. (3) organ. (4) system.
2. What is the pair of subatomic particles which attract each other?
 (1) electrons and neutrons (2) electrons and protons
 (3) protons and neutrons (4) electrons and electrons
3. The unit of momentum is
 (1) kg m s^{-1} . (2) kg m s^{-2} . (3) $\text{kg m}^{-1} \text{s}^{-1}$. (4) $\text{kg m}^2 \text{s}^{-2}$.
4. The figures A, B and C below indicate three types of muscle tissues.

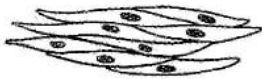

A

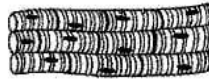

B



C

A, B and C above respectively are

- (1) smooth muscle, cardiac muscle and skeletal muscle tissues.
 - (2) skeletal muscle, smooth muscle and cardiac muscle tissues.
 - (3) smooth muscle, skeletal muscle and cardiac muscle tissues.
 - (4) cardiac muscle, skeletal muscle and smooth muscle tissues.
5. Which of the following is the molecule with highest number of covalent bonds?
 (1) O_2 (2) N_2 (3) NH_3 (4) CO_2
 6. Heat is transmitted from the Sun to the Earth by
 (1) radiation. (2) conduction.
 (3) convection. (4) radiation and convection.
 7. As was extracted by a student from an environmental pyramid, that ecosystem has one producer, eight primary consumers and twenty three secondary consumers. The student has extracted this information from a
 (1) upright number pyramid. (2) inverted number pyramid.
 (3) upright biomass pyramid. (4) inverted biomass pyramid.
 8. Here is shown the displacement-time graph of the motion of an object. During the time intervals from 0 to t_1 and t_1 to t_2 , the nature of the motion of the object respectively is,
 (1) a uniform velocity and an acceleration.
 (2) a uniform velocity and a retardation.
 (3) a uniform acceleration and a retardation.
 (4) a uniform retardation and an acceleration.

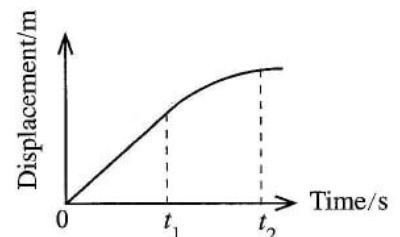

● Questions 9 and 10 are based on the following information and the illustration. Production of haemoglobin is disturbed by thalassemia, an inherited disease caused by the gene mutation in a somatic chromosome. With regard to the production of haemoglobin naturally, the dominant gene is T while the mutant recessive gene is t. A, B, C, and D indicate the F₁ generation.

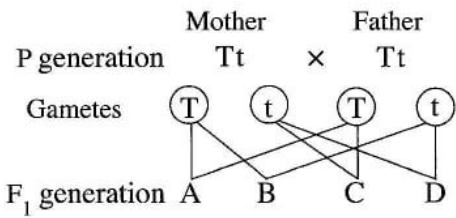

9. A thalassemia patient belonging to the F₁ generation is
 (1) A. (2) B. (3) C. (4) D.
10. The ratio among the thalassemia patients, healthy disease carriers and healthy individuals belonging to the F₁ generation is
 (1) 1 : 1 : 1. (2) 1 : 1 : 2. (3) 1 : 2 : 1. (4) 2 : 1 : 1.
11. Which statement is always true about the magnitude of displacement of a certain object?
 (1) greater than the distance moved (2) equal to the distance moved
 (3) lesser than the distance moved (4) either equal to or less than the distance moved
12. The electronic configurations of the atoms of two elements X and Y are 2, 8, 1 and 2, 8, 7 respectively. Of the following statements about the pair of those elements, which statement is **false**?
 (1) located in the same period in the Periodic Table
 (2) located in the same group in the Periodic Table
 (3) chemically combine forming ionic bonds
 (4) combine and form the compound with the chemical formula XY
13. What is the number of O₂ molecules contained in 64 g of oxygen gas? (O = 16)
 (1) 6.022×10^{23} (2) $2 \times 6.022 \times 10^{23}$ (3) $4 \times 6.022 \times 10^{23}$ (4) $64 \times 6.022 \times 10^{23}$
14. W, X, Y and Z are four elements consecutively placed in the Periodic Table with atomic numbers below 20. The graph indicates how their first ionisation energy (I₁) varies against the atomic number. In which group of the Periodic Table is Y placed?
 (1) I (2) II
 (3) III (4) IV

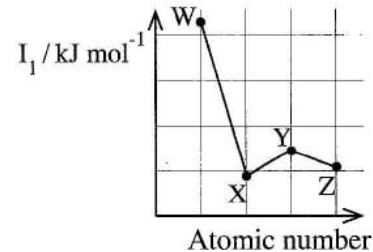

15. The substances acting as the main components providing energy for the functioning of the human body are
 (1) proteins and lipids. (2) proteins and vitamins.
 (3) carbohydrates and lipids. (4) carbohydrates and proteins.
16. A person's glucose level in the blood has increased above the optimum level. Which of the following food items should he consume minimally?
 (1) meat (2) milk (3) green gram (mung/payaru) (4) bread
17. Select the **false** statement about nucleic acids.
 (1) building unit is called nucleotide (2) a natural polymer
 (3) store hereditary information (4) contain the elements C, H, O and N only
18. Examples for the seeds/fruits dispersed by water, wind and explosive mechanism respectively are
 (1) Ceylon almond(kottamba/kaththappu), hora and mango. (2) lotus, castor (endaru/amanakku) and rubber.
 (3) coconut, milkweed (vara/erukkalai) and rubber. (4) jack, cotton and okra (bandakka/vendi).
19. Which of the following **does not** pass into the foetus from the mother through the umbilical cord?
 (1) blood (2) nutrients (3) oxygen (4) pathogens
20. What is the ray diagram which illustrates the phenomenon of total internal reflection?

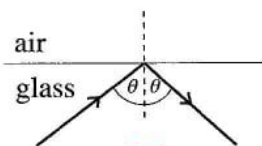

(1)

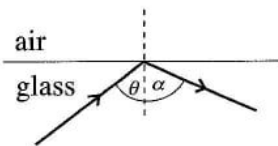

(2)

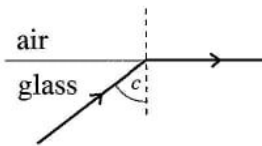

(3)

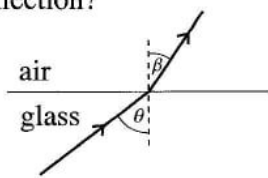

(4)

● Questions 9 and 10 are based on the following information and the illustration. Production of haemoglobin is disturbed by thalassemia, an inherited disease caused by the gene mutation in a somatic chromosome. With regard to the production of haemoglobin naturally, the dominant gene is T while the mutant recessive gene is t. A, B, C, and D indicate the F₁ generation.

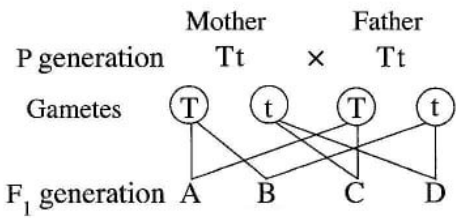

9. A thalassemia patient belonging to the F₁ generation is
 (1) A. (2) B. (3) C. (4) D.
10. The ratio among the thalassemia patients, healthy disease carriers and healthy individuals belonging to the F₁ generation is
 (1) 1 : 1 : 1. (2) 1 : 1 : 2. (3) 1 : 2 : 1. (4) 2 : 1 : 1.
11. Which statement is always true about the magnitude of displacement of a certain object?
 (1) greater than the distance moved (2) equal to the distance moved
 (3) lesser than the distance moved (4) either equal to or less than the distance moved
12. The electronic configurations of the atoms of two elements X and Y are 2, 8, 1 and 2, 8, 7 respectively. Of the following statements about the pair of those elements, which statement is **false**?
 (1) located in the same period in the Periodic Table
 (2) located in the same group in the Periodic Table
 (3) chemically combine forming ionic bonds
 (4) combine and form the compound with the chemical formula XY
13. What is the number of O₂ molecules contained in 64 g of oxygen gas? (O = 16)
 (1) 6.022×10^{23} (2) $2 \times 6.022 \times 10^{23}$ (3) $4 \times 6.022 \times 10^{23}$ (4) $64 \times 6.022 \times 10^{23}$
14. W, X, Y and Z are four elements consecutively placed in the Periodic Table with atomic numbers below 20. The graph indicates how their first ionisation energy (I₁) varies against the atomic number. In which group of the Periodic Table is Y placed?
 (1) I (2) II
 (3) III (4) IV

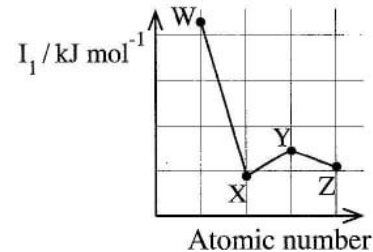

15. The substances acting as the main components providing energy for the functioning of the human body are
 (1) proteins and lipids. (2) proteins and vitamins.
 (3) carbohydrates and lipids. (4) carbohydrates and proteins.
16. A person's glucose level in the blood has increased above the optimum level. Which of the following food items should he consume minimally?
 (1) meat (2) milk (3) green gram (mung/payaru) (4) bread
17. Select the **false** statement about nucleic acids.
 (1) building unit is called nucleotide (2) a natural polymer
 (3) store hereditary information (4) contain the elements C, H, O and N only
18. Examples for the seeds/fruits dispersed by water, wind and explosive mechanism respectively are
 (1) Ceylon almond(kottamba/kaththappu), hora and mango. (2) lotus, castor (endaru/amanakku) and rubber.
 (3) coconut, milkweed (vara/erukkalai) and rubber. (4) jack, cotton and okra (bandakka/vendi).
19. Which of the following **does not** pass into the foetus from the mother through the umbilical cord?
 (1) blood (2) nutrients (3) oxygen (4) pathogens
20. What is the ray diagram which illustrates the phenomenon of total internal reflection?

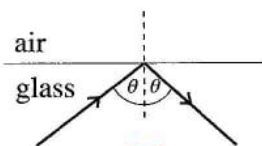

(1)

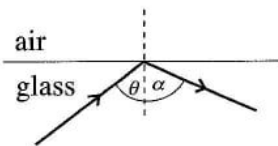

(2)

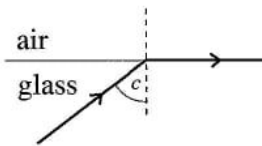

(3)

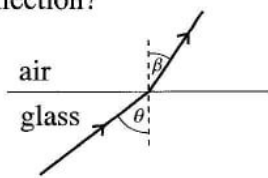

(4)

21. An athlete finishing a running event suffered from a cramp in his leg. What is the chemical compound which is produced in muscle cells causing the cramp?
 (1) carbon dioxide (2) ethyl alcohol (3) lactic acid (4) acetic acid
22. A warm-blooded (homoeothermic) animal and a cold-blood (poikilothermic) animal respectively are
 (1) pigeon and frog. (2) bear and rat. (3) rat snake and whale. (4) crocodile and tortoise.
23. Which arrangement can be used to obtain a voltage of 3 V from two dry cells each with an electromotive force of 1.5 V?

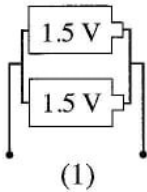

(1)

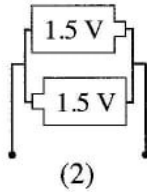

(2)

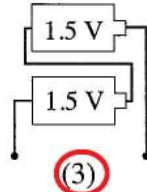

(3)

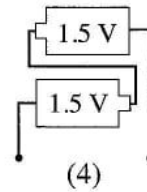

(4)

24. What is the metal that reacts with hot water but not with cold water?
 (1) sodium (2) magnesium (3) aluminium (4) calcium
25. What is the correct statement about the Covid-19 virus?
 (1) can be observed by the optical microscope (2) carries out metabolic activities
 (3) bears a nucleus with DNA (4) shows living as well as non-living characteristics
26. When salt is extracted from sea water in a saltern, what is the compound that precipitates along with NaCl?
 (1) Na_2SO_4 (2) MgCl_2 (3) CaCO_3 (4) CaSO_4
27. The maximum upthrust exerted by water on a certain object is less than the weight of the object. Then, the object will
 (1) float on the water surface. (2) float partly immersed in water.
 (3) float fully immersed in water. (4) sink fully in water.
28. What is the part common to the human digestive system and the human respiratory system?
 (1) mouth (2) oesophagus (3) pharynx (4) larynx
29. The figure shows how a couple of forces is applied to rotate a wheel of 0.4 m radius. How much is the moment of this couple?
 (1) $5 \times 0.4 \text{ Nm}$ (2) $5 \times 0.8 \text{ Nm}$
 (3) $5 \times 5 \times 0.4 \text{ Nm}$ (4) $5 \times 5 \times 0.8 \text{ Nm}$

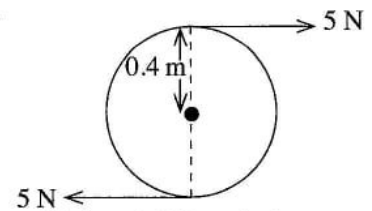

30. What is the mole fraction of O_2 in a mixture containing 96 g of oxygen gas (O_2) and 56 g of nitrogen gas (N_2)? ($N = 14, O = 16$)
 (1) $\frac{1}{5}$ (2) $\frac{2}{5}$ (3) $\frac{3}{5}$ (4) $\frac{4}{5}$
31. Given below are four ways by which zinc metal and hydrochloric acid were reacted at room temperature. In which way is hydrogen gas liberated with the highest speed?
 (1) zinc granules + dilute hydrochloric (2) zinc granules + concentrated hydrochloric
 (3) zinc powder + dilute hydrochloric (4) zinc powder + concentrated hydrochloric
32. Between a strong acid and a strong base,
 (1) an exothermic neutralization reaction occurs. (2) an endothermic neutralization reaction occurs.
 (3) an exothermic combination reaction occurs. (4) an endothermic combination reaction occurs.
33. A conductor carrying an electric current I , is kept perpendicular to a magnetic field as shown in the diagram. Horizontal lines indicate the direction of the magnetic field. The direction of the force acting on the conductor is
 (1) toward the left on the plane of the paper.
 (2) toward the right on the plane of the paper.
 (3) into the plane of the paper perpendicular to the plane.
 (4) out of the plane of the paper perpendicular to the plane.

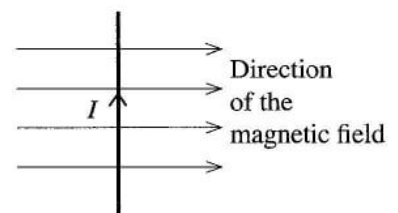

34. Under normal atmospheric pressure, a pure block of ice at temperature -10°C was heated at a uniform rate until it was turned into liquid water and then for some time after the water started to boil. Which graph correctly indicates the variation of the temperature of the system with time?

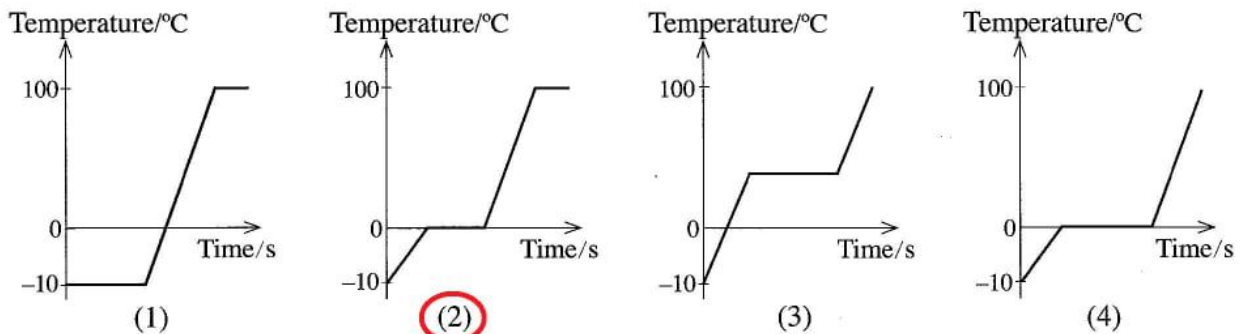

35. Consider the following statements presented regarding natural rubber.

- A - It is a linear polymer. B - Isoprene is the monomer. C - There are cross links among the chains.
Of these statements

- (1) only A is true. (2) only A and B are true.
(3) only B and C are true. (4) only A and C are true.

36. Corrosion of iron can be controlled by keeping iron in contact with the bivalent metal M. What is the half reaction to which the metal M is subjected here?

- (1) $\text{M(s)} \longrightarrow \text{M}^{2+}(\text{aq}) + 2\text{e}$ (2) $\text{M}^{2+}(\text{aq}) \longrightarrow \text{M(s)} + 2\text{e}$
(3) $\text{M}^{2+}(\text{aq}) + 2\text{e} \longrightarrow \text{M(s)}$ (4) $\text{M(s)} \longrightarrow \text{M}^{+}(\text{aq}) + \text{e}$

37. A 4 N force and a 3 N force are applied on an object at the same instance. Consider the following statements given about the magnitude of the resultant obtainable at that occasion.

- A - The maximum magnitude of the resultant obtainable is 7 N.
B - The minimum magnitude of the resultant obtainable is 1 N.
C - The magnitude of the resultant obtainable is always 5 N.

Of the above, the correct statement(s) is / are

- (1) only A. (2) only B. (3) only C. (4) only A and B.

38. A strong bar magnet is moved into and away from an insulated wire coil with a large number of turns as illustrated by the diagram. What is the correct observation about the instances of movement of the magnet?

- (1) In both instances, both the bulb and two LEDs light simultaneously.
(2) In both instances, the bulb lights and only one LED lights.
(3) The bulb and one LED light only when moved into the coil.
(4) The bulb and one LED light only when moved away from the coil.

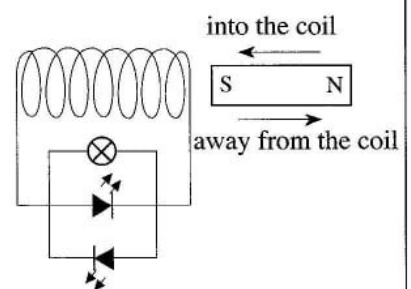

39. Consider the following statements.

- A - Biomagnification occurs along a food chain.
B - Toxic chemical pollutants concentrate more in the upper trophic levels of a food chain.

Of the above statements,

- (1) both A and B are true. (2) A is true while B is false.
(3) A is false while B is true. (4) both A and B are false.

40. A statement displayed on a board near a tank is shown in the figure. Which of the following human activities in connection with the tank would have contributed most to the change mentioned on the board?

- (1) clearing the area above the tank
(2) increase in algae population due to fishing
(3) accumulation of oil and grease due to vehicle wash
(4) addition of faecal and excretory matter to the water

"It is you who turned the water in this tank green"