

Final Term Test – June 2015

Grade 13

PHYSICS I

Time : - 2 hours

- Answer all questions. ( $g = 10 \text{ Nkg}^{-1}$ )

(01) Speed of sound in a gas ( $V$ ) is given by  $V = \sqrt{\gamma K_B T / m}$  Where;  $\gamma$  - a dimensionless constant  $m$ - mass  $T$ - absolute temperature. Units of  $K_B$  is;

- (1)  $\text{kgm}^2\text{s}^{-2}\text{K}^{-1}$                       (2)  $\text{kg}^{-1}\text{m}^2\text{s}^2\text{K}$                       (3)  $\text{kgms}^2\text{K}$   
 (4)  $\text{kgm}^2\text{s}^{-1}$                       (5)  $\text{kgm}^2\text{s}^2\text{K}$

(02) The physical quantity implied by the relation  $FV^3a^2$  (where;  $V$ - velocity  $a$  -acceleration  $F$ - force) is;

- (1) Energy                      (2) Power                      3) Angular momentum  
 (4) Linear momentum                      (5) Torque

(03) A projectile having a time of flight 2s would reach a maximum height of;

- (1) 40m                      (2) 30m                      (3) 20m                      (4) 10m                      (5) 5m

(04) Two particles  $m_1$  and  $m_2$  ( $m_1 > m_2$ ) which were initially at rest at separation  $r$  attracts each other according to inverse square law. Which of the following statements is true about their centre of mass (COM)?

- (1) COM moves towards  $m_1$  at uniform velocity.  
 (2) COM moves towards  $m_2$  at uniform velocity.  
 (3) COM doesn't move.  
 (4) COM moves towards  $m_1$  at uniform acceleration  
 (5) COM moves towards  $m_2$  at uniform acceleration

(05) 1.2A current flows across a  $10^{-4} \text{ m}^2$  cross section of a conductor having free electron density  $5 \times 10^{28} \text{ m}^{-3}$ . (Charge of an electron  $1.6 \times 10^{-19} \text{ C}$ ) The drift velocity of electrons is;

- (1)  $1.5 \times 10^{-2} \text{ ms}^{-1}$                       (2)  $1.5 \times 10^{-3} \text{ ms}^{-1}$                       (3)  $1.5 \times 10^{-4} \text{ ms}^{-1}$   
 (4)  $1.5 \times 10^{-5} \text{ ms}^{-1}$                       (5)  $1.5 \times 10^{-6} \text{ ms}^{-1}$

(06) Two masses  $m_1$  and  $m_2$ , attached at the ends of a spring, placed on a smooth horizontal table. When  $m_2$  acquires an acceleration 'a' due to a horizontal force 'F' acting on it, the acceleration of  $m_1$  at the same instance is;

- (1)  $\frac{F - m_1 a}{m_1 + m_2}$                       (2)  $\frac{F - m_2 a}{m_2}$                       (3)  $\frac{F - m_1 a}{m_1}$

- (07) Two metal wires A and B, made of the same material weigh 12g and 18g respectively. The ratio between their lengths is 3 : 4. The ratio between their resistance ( $R_A : R_B$ ) is;

- (1) 27 : 32      (2) 4 : 3      (3) 9 : 18      (4) 18 : 27      (5) 2 : 9

- (08) A layer of oil ( $\tau = 1.5 \text{ Nsm}^{-2}$ ) of thickness  $10^{-5} \text{ m}$  is applied between a plate of area  $0.1 \text{ m}^2$  and a planar surface. The plate slides on the planar surface at  $1 \text{ mms}^{-1}$  constant speed. The corresponding force applied is;

- 1) 1.5 N    2) 15 N    3) 150 N    4) 100N    5) 50N

- (09) Speed of a certain light ray (of frequency  $6 \times 10^{14} \text{ Hz}$ ) in vacuum is  $3 \times 10^8 \text{ ms}^{-1}$ . Its speed ( $V$ ) and frequency ( $f$ ) in a medium of refractive index 2.5 are;

	$V(\text{ms}^{-1})$	$f(\text{Hz})$
(1)	$1.5 \times 10^8$	$12 \times 10^{14}$
(2)	$1.5 \times 10^8$	$6 \times 10^{14}$
(3)	$1.2 \times 10^8$	$6 \times 10^{14}$
(4)	$1.5 \times 10^8$	$6 \times 10^{14}$
(5)	$3 \times 10^8$	$12 \times 10^{14}$

- (10) Prism angle was found to be  $60^\circ$  using the spectrometer configuration shown here, which read the position of the telescope  $T_1 = 68^\circ 12'$ . The reading at position  $T_2$  is;

- (1)  $128^\circ 12'$   
 (2)  $218^\circ 12'$   
 (3)  $288^\circ 12'$   
 (4)  $248^\circ 12'$   
 (5)  $308^\circ 12'$



- (11) A circular loop of wire having a single turn is then folded to make three turns within the available length. The same current is sent through the wire in both situations. The magnetic flux density at the centre of the loop in situation 1 and 2 are  $B_1$  and  $B_2$  respectively. The ratio  $B_1 / B_2$  is equal to;

- (1) 9                      (4)  $\frac{1}{6}$   
 (2)  $\frac{1}{3}$                     (5)  $\frac{1}{9}$   
 (3) 3



(12)

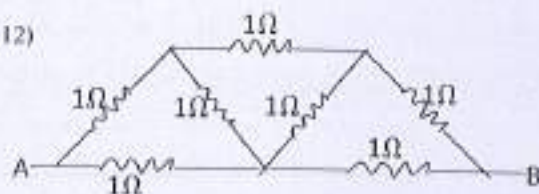

Equivalent resistance between A and B;

- (1)  $\frac{4}{3}\Omega$       (2)  $\frac{3}{2}\Omega$       (3)  $7\Omega$       (4)  $\frac{8}{7}\Omega$       (5)  $\frac{8}{3}\Omega$

(13)

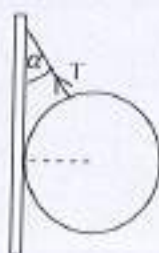

A uniform sphere of mass  $m$  is attached to a string at its circumference, which is tied to a rough wall from the opposite end as shown here. The sphere in contact with the wall is in equilibrium, while the string is an  $\alpha$  angle inclined to the wall.  $\mu$  - coefficient of friction between the sphere and the wall. Which of the following gives the tension of the string?

- (1)  $mg - \mu mg \sin \alpha$       (2)  $\frac{mg}{\mu \sin \alpha - \cos \alpha}$       (3)  $mg + \mu mg \sin \alpha$   
 (4)  $\frac{mg}{\mu \cos \alpha + \sin \alpha}$       (5)  $\frac{mg}{\mu \sin \alpha + \cos \alpha}$

- (14) The variation of torque ( $\tau$ ) applied on an object of moment of inertia  $10\text{kgm}^2$  which was at rest is shown here. Angular velocity of the object after 30s (in  $\text{rads}^{-1}$ );

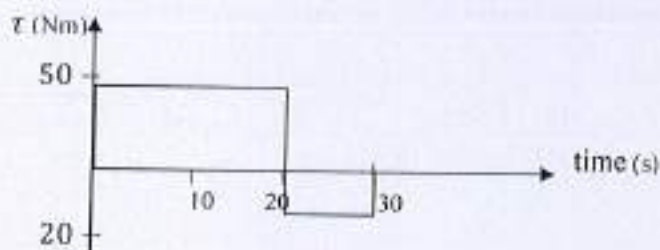
Angular velocity of the object after 30s (in  $\text{rads}^{-1}$ );

- (1) 20      (2) 40      (3) 60      (4) 80      (5) 100
- (15) A rock of mass 1.1kg is tied to an Aluminum string (of length 1m and of diameter 0.4mm) which is suspended vertically from the fixed end. Now the rock is rotated in a horizontal plane, as the string is inclined  $60^\circ$  with the vertical. Young's modulus for Al =  $7 \times 10^{10}\text{Nm}^{-2}$ . The extension of the length of the string is;

- (1) 6.25mm      (2) 2.5mm      (3) 0.625mm      (4) 0.25mm      (5) 3.125mm

- (16) An electron of an atom emits radiation of wavelength  $\lambda$  and velocity  $c$  when jumping from its existing energy state  $E_1$  to a higher energy state  $E_2$ . Which of the following relationships is correct?

(1)  $\lambda = \frac{h(E_1 - E_2)}{c}$       (2)  $\lambda = h(E_1 - E_2)$       (3)  $\lambda = \frac{c}{h(E_1 - E_2)}$   
 (4)  $\lambda = \frac{hc}{E_1 - E_2}$       (5)  $\lambda = \frac{(E_1 - E_2)c}{h}$

(17)

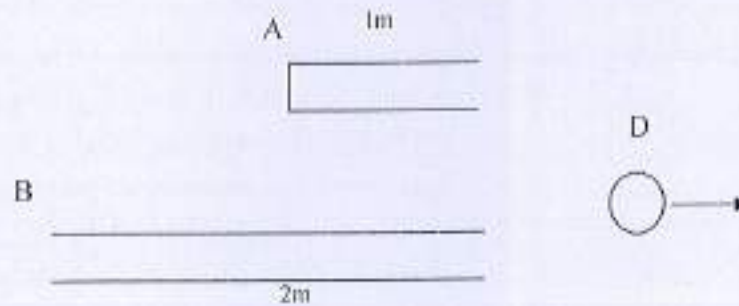

A is 1m long closed tube while B is 2m long open tube. Both resonate at their 3<sup>rd</sup> harmonic. D is a detector which is moving away from the tubes. Which of the following relation/s is/ are correct?  $V$  – speed of sound in air.

	Speed of D (in terms of $V$ )	frequency as detected by D
a)	$2V/3$	fundamental tone of A
b)	$2V/3$	fundamental tone of B
c)	$4V/5$	fundamental tone of A
d)	$4V/5$	fundamental tone of B

- (1) a only      (2) b only      (3) c only  
 (4) a and c only      (5) b and c only

- (18) A uniform rod of mass 'm' is hinged to the wall at one of its ends. The rod is held in equilibrium by a string (tied to the wall) from its opposite end.  $\theta_1 = 60^\circ$ . Tension of the string is  $\frac{mg}{2}$ ,  $\theta_2$  is equal to;

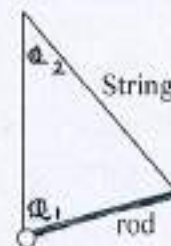

- (1)  $15^\circ$       (2)  $30^\circ$       (3)  $45^\circ$       (4)  $60^\circ$       (5)  $75^\circ$



- (19) Shown here is the variation of apparent weight with the depth submerged ( $h$ ) for an object of rectangular cross section when immersed in three different liquids a, b, c. Which is the correct ascending order of their densities?

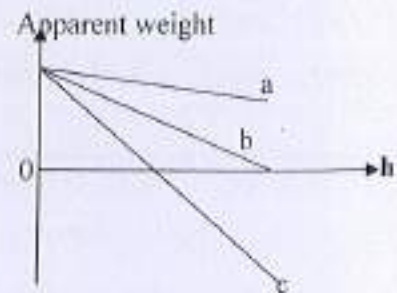

- (1)  $a < b < c$                       (2)  $a < c < b$   
 (3)  $b < c < a$                       (4)  $c < b < a$   
 (5)  $c < a < b$
- (20) Which of the following accurately describe the image formed by a virtual object placed in front of the convex lens at a distance greater than  $2F$  on its principal axis??
- (1) Upright, virtual, diminished  
 (2) inverted, real, same size as the object  
 (3) upright, real, diminished  
 (4) inverted, virtual, diminished  
 (5) inverted, real, magnified

- (21) The circuit set up produces a variable potential difference between P and Q using the sliding key P. The range of potential difference obtained between P and Q;

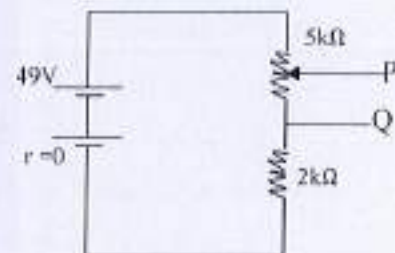

- (1) 0-25V                      (2) 0-10V                      (3) 0-15V  
 (4) 0-35V                      (5) 0-45V
- (22) Two waves A and B of equal wavelength  $\lambda$  travel towards right starting from the same phase. Though wave A is being reflected by 4 surfaces, it travels towards the initial direction in the end. To make the waves A and B travel in opposite phases in the end the minimum value that L should take in terms of  $\lambda$  is;

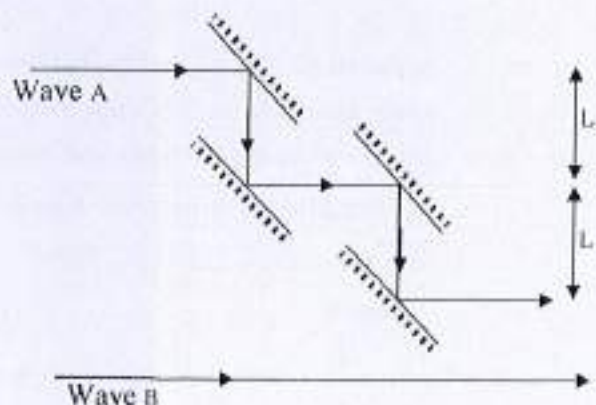

- (1) 0.5                      (2) 0.25                      (3) 0.75                      (4) 0.4                      (5) 0.6

(23) Which of the following statement/s is are true about 4 identical particles placed at 3 different configurations shown here?

- a) Gravitational force on the particle at the centre of the circle is maximum in c.
- b) Gravitational potential of the system is maximum in c.
- c) Gravitational force on the particle at the centre of the circle is minimum in a.
- d) Gravitational potential of the system is minimum in b.

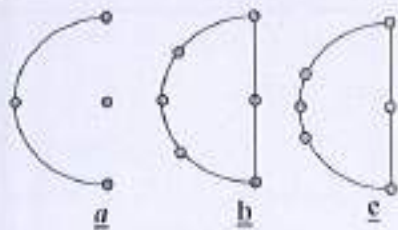

- (1) a and b
- (2) b and c
- (3) c and d
- (4) a, b and c
- (5) All a, b, c, d

(24) Which of the following possible experimental errors are more effective in an experiment to determine latent heat of vaporization of steam by sending steam into water contained in a calorimeter?

- a) heat loss to the surrounding during the experiment.
- b) heat loss due to the addition of wet steam.
- c) evaporation of water in the calorimeter.
- d) a fraction of steam being condensed inside the steam trap

- (1) a, c, d
- (2) a, d
- (3) a, b
- (4) a, b, c
- (5) all a,b, c,d

(25) Electromagnetic radiation of frequency  $f$  and intensity  $I$  incidents on a photo cathode, which results a photo current ( $i$ ).  $V$  is the potential supplied to the photocell. Shown here is the variation of  $i$  with  $V$ . Given in broken lines is the  $i-V$  variation when the intensity of the light is doubled at the same frequency  $f$ . Which of the given graphs shows the correct variation?.

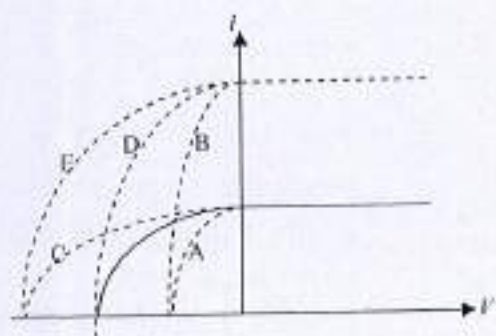

- (1) A
- (2) B
- (3) C
- (4) D
- (5) E



- (26) A vehicle travels at uniform speed  $V$  on a road in the hills; climbing peaks and sloping down troughs each of radius  $R$ . The driver of the vehicle feels weightless most probably;

- (1) at the peak when  $V < \sqrt{gR}$   
 (2) at the foot when  $V < \sqrt{gR}$   
 (3) moving down the slope at  $V = \sqrt{gR}$   
 (4) at the foot when  $V > \sqrt{gR}$   
 (5) at the peak when  $V > \sqrt{gR}$



- (27) A shunt of resistance  $2\Omega$  is connected across a galvanometer of internal resistance  $98\Omega$ .  $I_0$  – total current entering the galvanometer system  $I$  – current flowing through the galvanometer. The ratio  $I/I_0$  is equal to;

- (1)  $\frac{1}{2}$                       (2)  $\frac{1}{3}$                       (3)  $\frac{1}{98}$                       (4)  $\frac{1}{100}$                       (5)  $\frac{1}{50}$

- (28) A closed cyclic thermodynamic process for a gas is shown here. From  $c$  to  $b$   $40\text{J}$  of heat energy is removed from the gas. From  $b$  to  $a$   $130\text{J}$  of heat energy is removed from the gas and work of  $80\text{J}$  is done on the gas. From  $a$  to  $c$   $400\text{J}$  of heat energy is supplied to the gas. Work done by the gas from  $a$  to  $c$  is;

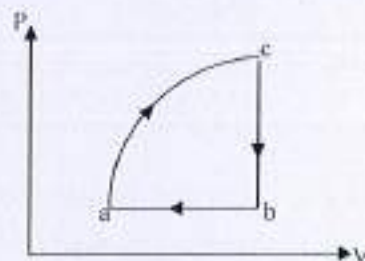

- (1)  $490\text{J}$                       (2)  $310\text{J}$                       (3)  $150\text{J}$                       (4)  $410\text{J}$                       (5)  $450\text{J}$

- (29) A DC motor operated at  $200\text{V}$  draws  $5\text{A}$  current at the start. Later, during the functioning, it only draws  $3\text{A}$  current. The back e.m.f. generated in the motor;

- (1)  $200 \times \frac{3}{5}\text{V}$                       (2)  $200 \times \frac{2}{5}\text{V}$                       (3)  $200 \times \frac{5}{3}\text{V}$   
 (4)  $200 \times \frac{1}{3}\text{V}$                       (5)  $200\text{V}$

- (30) ABCD is a circular conducting wire of centre  $O$ . A cell is connected across A-C.  $\angle AOC = 60^\circ$ , Magnetic flux densities at the centre  $O$ , due to the currents flowing through the routes ABC and ADC are  $B_1$  and  $B_2$  respectively. The ratio  $B_1/B_2$  is equal to;

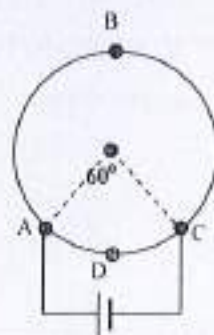

- (1) 5                      (2)  $\frac{1}{5}$                       (3) 6                      (4) 1                      (5)  $\frac{1}{6}$

- (31)  $F_1$  and  $F_2$  are two fish at the bottom of a tank filled with water upto 80cm depth.  $C$  is the critical angle for water air interface.  $F_1$  can directly see  $F_2$  and also the image of  $F_2$  vertically right above the water level in air. The height above the water surface level to the image of  $F_2$  (in cm) is;

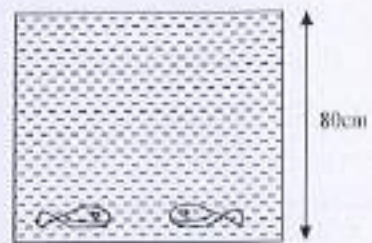

- (1)  $80 \sin c$  (2)  $\frac{80}{\sin c}$  (3)  $80 \tan c$   
 (4)  $\frac{80}{\tan c}$  (5) 80

- (32) The balance point obtained for a metre bridge set up having  $10\Omega$  resistor and a parallel combination of  $40\Omega$  and ( $X\Omega$ ) unknown resistor is obtained at 25cm.  $X$  is equal to;

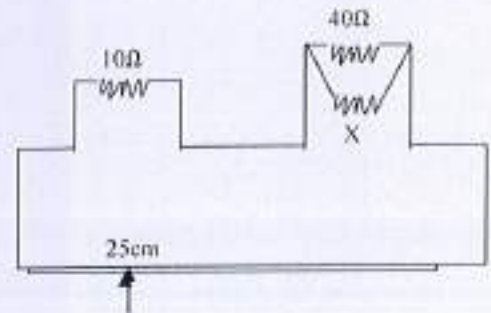

- (1)  $40\Omega$  (2)  $50\Omega$  (3)  $60\Omega$  (4)  $100\Omega$  (5)  $120\Omega$

- (33)  $AB$  is a straight long conductor carrying 20A current through it.  $CDFG$  is a rectangular conducting loop of area  $20\text{cm} \times 9\text{cm}$  passing 10A current through it.  $CG$  and  $AB$  is parallelly separated by 1cm. Force by  $AB$  on the rectangular conducting loop is;  
 ( $\mu_0 = 4\pi \times 10^{-7} \text{Hm}^{-1}$ )

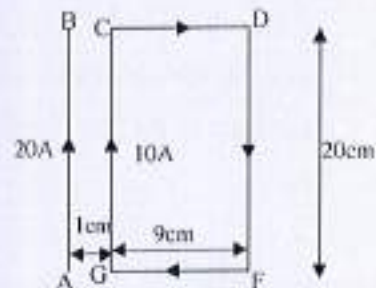

- (1)  $3.6 \times 10^{-4} \text{N}$  towards left (2)  $7.2 \times 10^{-4} \text{N}$  towards right  
 (3)  $3.6 \times 10^{-4} \text{N}$  towards right (4)  $7.2 \times 10^{-4} \text{N}$  towards left  
 (5)  $1.8 \times 10^{-4} \text{N}$  towards right
- (34) Which of the following statement/s is/are true about a compound microscope?  
 a) Image by the objective is formed on the cross wires at the normal adjustment.  
 b) Linear magnification of the eye piece increases as the focal length of the eye piece increases.  
 c) A short sighted person should shift the eye piece towards him to see a clear image from the compound microscope at its' normal adjustment.

- (1) a only (2) b only (3) c only  
 (4) a and c only (5) all a, b, c



(35) The balance length obtained (from potentiometer) for a cell of e.m.f. 1.5V is 60cm. The potential drop across the 1m full length of the potentiometer wire is;

- (1) 0.5V      (2) 1V      (3) 1.5V      (4) 2.5V      (5) 1.75V

(36) Two charged particles A and B of masses  $m_A$  and  $m_B$  respectively; are moving on the same plane at velocities  $v_A$  and  $v_B$ , perpendicular to a uniform magnetic field, their following expressions is true?

- (1)  $m_A v_A > m_B v_B$   
 (2)  $m_A v_A < m_B v_B$   
 (3)  $m_A < m_B$  and  $v_A > v_B$   
 (4)  $m_A = m_B$  and  $v_A = v_B$   
 (5)  $m_A v_A = m_B v_B$



(37) A loop of wire of the given shape is moved at uniform  $V$  speed perpendicular to the uniform magnetic field. The variation of induced e.m.f. across the loop ( $E$ ) with distance ( $r$ ) is correctly depicted in;

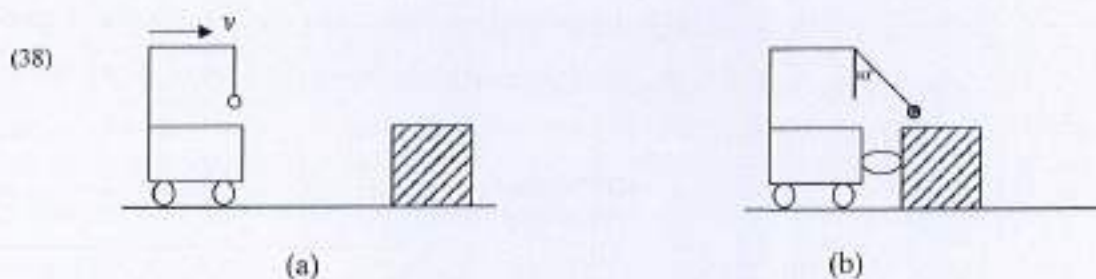
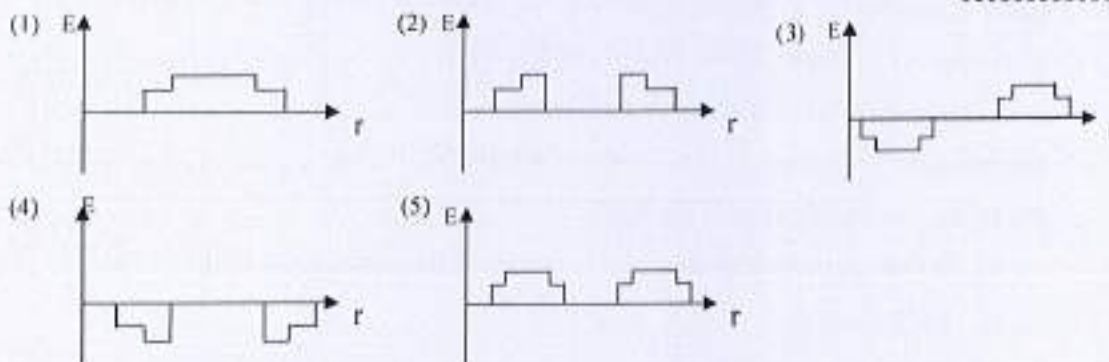
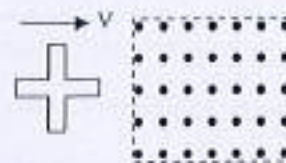

a) A cart with a pendulum fixed on top is moving at uniform speed  $V$ , towards a wooden block.

b) The cart hits the wooden block and get stuck to it, as the pendulum showed  $60^\circ$  inclination to the vertical. The length of the pendulum string is 1.6m.  $V$  is equal to;

- (1)  $2\text{ms}^{-1}$       (2)  $2.4\text{ms}^{-1}$       (3)  $3\text{ms}^{-1}$       (4)  $3.6\text{ms}^{-1}$       (5)  $4\text{ms}^{-1}$

- (39) The two shells  $S_1$  and  $S_2$  contains charges  $Q$  and  $2Q$ . Flux through  $S_1$  is  $\phi_1$  and through  $S_2$  is  $\phi_2$ . When a medium of dielectric constant 5 is inserted into  $S_1$ , the flux through it  $S_1$  became  $\phi_3$ .  $\epsilon_0$  - permittivity of free space. Which of the following accurately gives the ratio  $\phi_1/\phi_2$  and  $\phi_3$ .

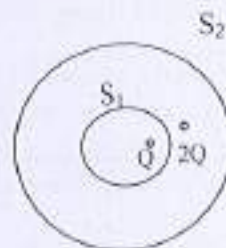

	(1)	(2)	(3)	(4)	(5)
$\frac{\phi_1}{\phi_2}$	3	$\frac{1}{3}$	$\frac{1}{3}$	$\frac{3}{2}$	$\frac{3}{2}$
$\phi_3$	$\frac{Q}{5\epsilon_0}$	$\frac{5Q}{\epsilon_0}$	$\frac{Q}{5\epsilon_0}$	$\frac{Q}{5\epsilon_0}$	$\frac{Q}{5\epsilon_0}$

- (40)  $q_1$  and  $q_2$  charges are placed at the points of a rectangle of length 15cm and breadth 5cm.  $q_1 = -3\mu\text{C}$ ,  $q_2 = 2\mu\text{C}$ .  $1/4\pi\epsilon_0 = 9 \times 10^9 \text{Nm}^2\text{C}^{-2}$ . Electrostatic potential at infinity is zero. Which of the following statement/s is/are true?

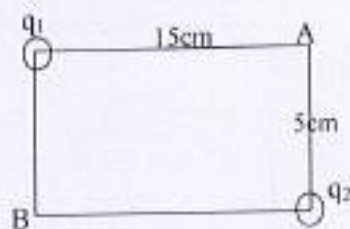

- When carrying a charge of  $+5\mu\text{C}$  from B to A along the straight path BA, 3J of work is done.
- Electrostatic potential energy of the system increase once the charge is carried.
- The amount of work done in carrying the charge along the BA diagonal is greater than the amount of work done in carrying the charge from B to A along the sides of the rectangle.

(1) a only

(2) bonly

(3) a, b

(4) b, c

(5) a, b, c

- (41) A uniform rod of length 0.6m and moment of inertia  $0.12\text{kgm}^2$  about the axis of rotation, hits and get stuck to a ball of clay of mass 0.2kg at its' vertical position. While rotating at  $2.4\text{rads}^{-1}$  angular velocity, as shown here. Angular velocity of the system after collision is;

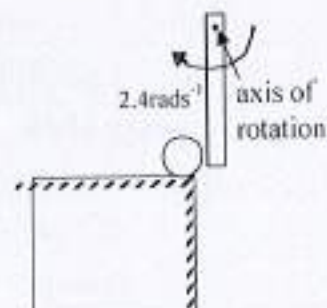



- (1)  $1.2\text{rads}^{-1}$       (2)  $1.5\text{rads}^{-1}$       (3)  $1.8\text{rads}^{-1}$   
 (4)  $2.0\text{rads}^{-1}$       (5)  $2.1\text{rads}^{-1}$

(42) A hollow sphere and a hollow cube (with thin walls and equal areas of surface, made of the same material) are filled with hot water and placed in a constant temperature room. Temperature of the room is a few degree less than the temperature of water. Which of the following statement/s is / are true?

- a) rate of heat loss from the sphere is greater than that from the cube.  
 b) rate of heat loss from the sphere is less than that from the cube.  
 c) rate of temperature loss from the sphere is less than that from the cube.  
 d) rates of heat loss from both objects are equal.

- (1) a, c      (2) b, c      (3) a, d      (4) b, d      (5) c, d

(43) The two zener diodes connected in the circuit are used as voltage stabilizers. Zener voltage for the diodes are  $V_z = 10\text{V}$  and the maximum current for the diodes  $I_z = 200\text{mA}$ .  $R_1 = 20\text{k}\Omega$  (the most suitable value for)  $R_s$  would be;

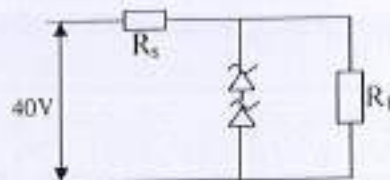

- (1)  $10\Omega$       (2)  $20\Omega$       (3)  $40\Omega$       (4)  $50\Omega$       (5)  $100\Omega$

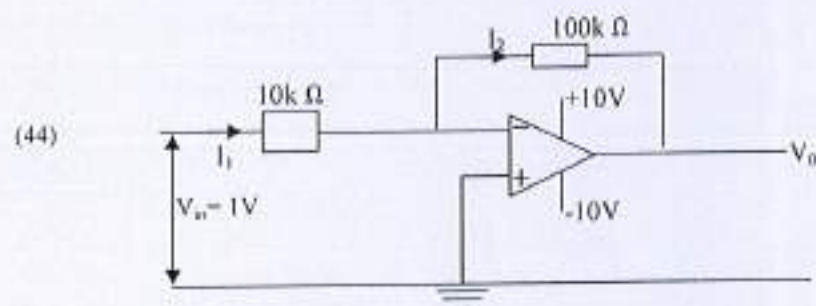

In the amplifying circuit shown here, the current  $I_1$  is equal to;

- (1)  $0.1\text{A}$       (2)  $0.2\text{A}$       (3)  $0.1\text{mA}$       (4)  $1\text{mA}$       (5)  $10\text{mA}$

(45) ABC is an isosceles rectangular prism. A pin PQ is placed in front of AB face of the prism. Which of the following statement/s is/are true?

- a) A laterally inverted image of PQ is observed from  $E_1$   
 b) The image observed from  $E_1$  is real.  
 c) An image is not observed when looked from  $E_2$

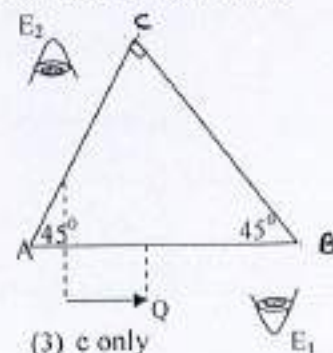

- (1) a only      (2) b only  
 (4) a, b only      (5) all a, b, c

- (46) Height of Mercury column in a barometer is 70cm due to some air been escaped into the 10cm long space above Hg.  
Now the Hg tube of the barometer is pushed down a little into the dish of Hg. Then the height of space above Hg in the tube became 6cm for the height of the Hg column in the tube 67cm. The true value of the atmospheric pressure is;

- (1) 74.5 cmHg (2) 75cm Hg (3) 75.5 cmHg  
(4) 76 cmHg (5) 76.5 cmHg

- (47) Which of the following combination is not valid for an S-R flip flop?  
(1)  $S = 0, R = 0$  (2)  $S = 1, R = 0$  (3)  $S = 0, R = 1$   
(4)  $S = 1, R = 1$  (5) None of the above

- (48) A horizontal circular loop of wire (of radius 2cm) weighing  $5.4 \times 10^{-3}$ N required  $14.2 \times 10^{-3}$ N force to be raised from a liquid surface. Surface tension of the liquid on which the wire had been placed is;

- (1)  $1.75 \times 10^{-2}$  (2)  $2.5 \times 10^{-2}$  (3)  $3.5 \times 10^{-2}$  (4)  $4.5 \times 10^{-2}$  (5)  $7 \times 10^{-2}$

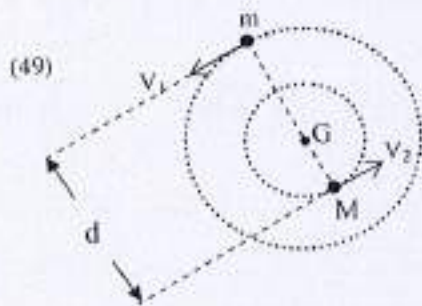

Two stars of masses  $m$  and  $M$  at separation  $d$  are rotating in circular orbits at time period  $T$  about their centre of mass.  $G$ - universal gravitational constant.  $T^2$  is correctly expressed in ;

- (1)  $T^2 = \frac{4\pi^2 d^3}{G(M+m)}$  (2)  $T^2 = \frac{4\pi^2 d^3}{G(M+m)}$  (3)  $T^2 = \frac{4\pi^2 d^3 M}{G(M^2+m^2)}$   
(4)  $T^2 = \frac{4\pi^2 d^3 m}{G(M^2+m^2)}$  (5)  $T^2 = \frac{4\pi^2 d^3}{G M m}$

- 50) When the rotating plane of the armature of a current generator aligns parallel to the magnetic field,

- 1) the magnetic flux linked with the armature and its' electromotive force are zero.
- 2) the magnetic flux linked with the armature is zero but the induced e.m.f is maximum.
- 3) the magnetic flux linked with the armature is maximum but the induced e.m.f is minimum.
- 4) the magnetic flux linked with the armature and induced e.m.f both are at their maxima.
- 5) the magnetic flux linked with the armature and induced e.m.f both are at moderate values.



APB

Final Term Test – June- 2015  
Grade 13  
PHYSICS II

Time : - 3 hours

Gravitational field intensity  $g = 10 \text{Nkg}^{-1}$

Part A – Structured Essay

❖ Answer all 4 questions on this paper itself.

(1) (a) A mass  $M$  connected to spring of spring constant  $K$  oscillates at amplitude  $A$  on a smooth horizontal table. The spring of negligible mass is rigidly fixed at  $P$ . When  $M$  passes the equilibrium position a small ' $m$ ' mass is placed on it (The friction between  $m$  and  $M$  is sufficient to give ' $m$ ' the velocity of  $M$ ) Now the system oscillates simple harmonically.

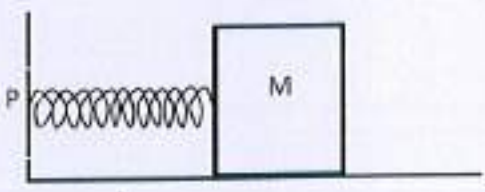

(i) Obtain an expression for the velocity of  $M$  as it passes the equilibrium position ( $V$ ) in terms of  $M$ ,  $A$  and  $K$ .

.....  
.....

(ii) Obtain an expression for the velocity of the system (after  $m$  placed on  $M$ ) as it passes the equilibrium position, in terms of  $M$ ,  $m$  and  $V$ .

.....  
.....

(iii) Obtain an expression for the amplitude of the system in terms of  $A$ ,  $M$  and  $m$ .

.....  
.....  
.....

(iv) ~~harmonically~~ Would the mechanical energy of the system reduce? Explain.

.....  
.....  
.....



- (b) Now  $M$  and the spring is used in an experiment to determine the coefficient of dynamic friction ( $\mu_K$ ) between the rough surface and  $M$ . A light inextensible string connected to  $M$  runs over a smooth pulley at the end of the rough horizontal surface and its free end is connected to a light scale pan while the spring is tied to a fixed support. The spring is not under tension for the situation shown here.

When a mass  $m$  is placed on the scale pan, the pan shifts its position an  $x$  distance down. Accordingly  $M$  too moves an  $x$  distance and the extension of the spring becomes  $x$ .

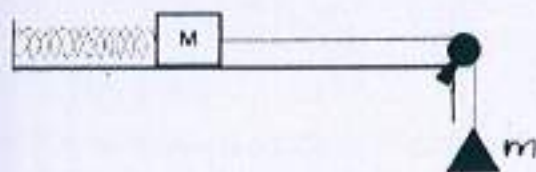

- (i) Obtain an equation for the variation of  $x$  with  $\frac{m}{M}$  based on the Work-Energy principle.

.....  
 .....

- (ii) Arrange the variables in the above equation to plot a graph.

.....  
 .....

Shown below is a set of readings obtained in the above experiment.

- { 3 } ii) 9) If the temperature of water remained steady at  $70^{\circ}\text{C}$  (instead of  $60^{\circ}\text{C}$ ), what is the power out put from the flames? }

$m$ (g)	650	700	750	800	850
$X$ (cm)	9.0	18.0	27.0	35.0	44.0

- (iii) Plot the graph of  $x$  Vs  $m$ .

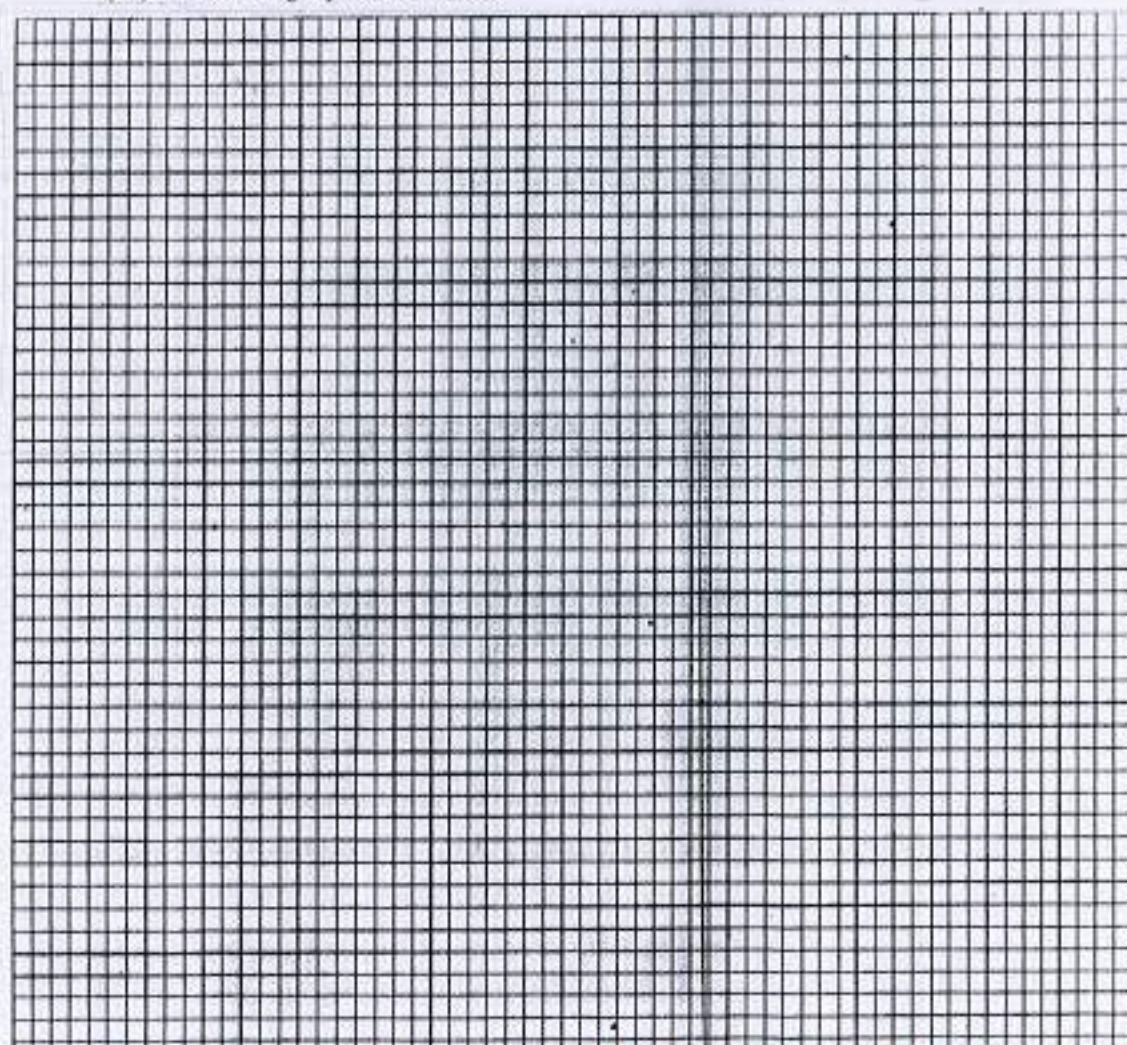



(iv) Find the gradient of the graph.

.....  
.....  
.....

(v) Find the intercept of the graph.

.....  
.....  
.....

(vi) If  $M = 700\text{g}$  calculate  $\mu_K$

.....  
.....

(2) Sonometer and a vibrating tuning fork are used to determine the variation of fundamental resonance length of a wire with the tension of the wire (T).

(i) What is the reason for using a hollow wooden box in the sonometer?

.....  
.....

(ii) Explain briefly how you would find the fundamental resonance length of the wire for different values of its' tension.

.....  
.....  
.....  
.....  
.....

(iii) Write down an equation for the frequency of the tuning fork (f) for which a 'l' length of the string resonates at its' fundamental when 'M' mass is attached at the free end of the string whose linear density is 'm'.

.....

(iv) Gradient of the Graph of  $l$  Vs  $\sqrt{M}$  obtained from a similar experiment was  $\frac{5}{64} \text{ mkg}^{-\frac{1}{2}}$ . Find the mass per unit length of the wire if  $f = 512 \text{ Hz}$ .

.....  
.....  
.....  
.....

(v) The result obtained in (iv) above can be used to find the density of the string material. What is the additional measurement you may need in this regard?

.....

What is the measuring instrument you should use to take that measurement?

.....

(vi) Write down an expression for the density of the string material in terms of 'm' and the above measurement.

.....

.....

(vii) Some musical instruments produce musical notes by means of stationary waves along a set of stretched strings, either of varying diameter or density. Explain, how these string instruments produce different musical notes based on the above phenomenon.

.....

.....

.....

.....

(3) (i) Show the direction of heat flow through the rods a) and b) using lines ending with arrow heads.

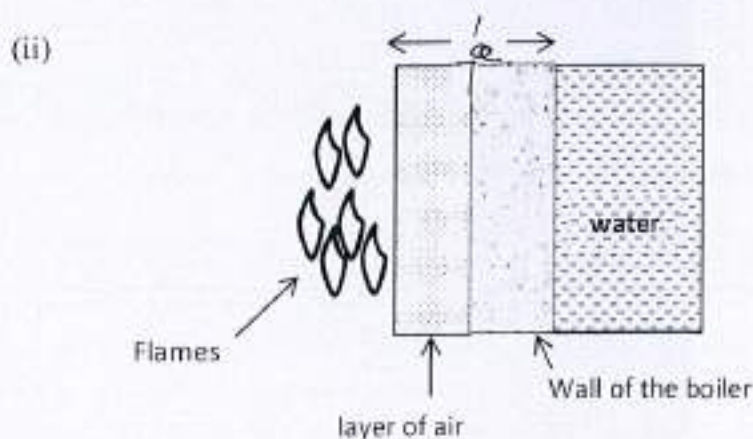
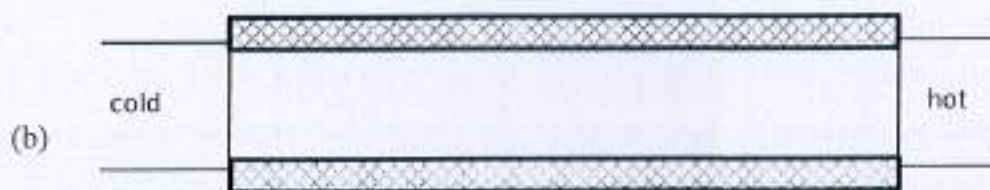
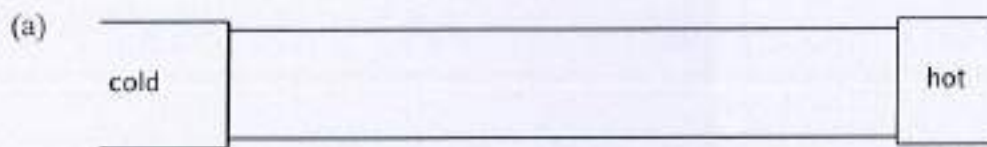



In an experiment to determine the thermal conductivity of the material from which a boiler is made; 2kg of water in the boiler which was initially at the room temperature was heated by a flame of temperature  $200^{\circ}\text{C}$ . Temperature of water raised to  $60^{\circ}\text{C}$  from room temperature  $30^{\circ}\text{C}$  within 5 minutes and then remained constant. Specific heat capacity of water  $4000\text{Jkg}^{-1}\text{K}^{-1}$ .

- a) Thickness of the layer of air  $= \frac{l}{2}$  Sketch the variation of temperature  $\theta$  with  $l$ .  
(Ignore the heat loss to the surrounding along the length  $l$ )

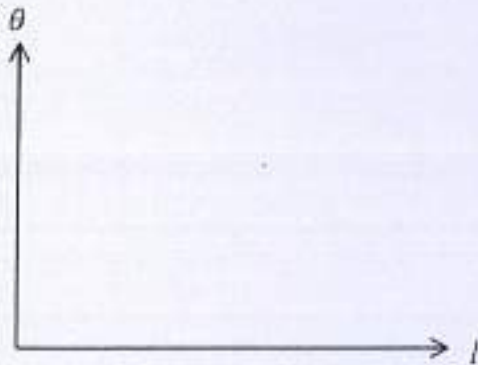

- b) Explain why the temperature of water remained steady after being increased to  $60^{\circ}\text{C}$ .

.....  
 .....  
 .....

- c) Work out the rate of heat absorption by water.

.....  
 .....  
 .....

- d) What is the corresponding power delivered by the flames?

.....

- e) Write down an expression for the temperature of air in contact with the wall of the boiler ( $\theta$ ) in terms of  $A$  (area of the wall of the boiler) and  $K_l$  (thermal conductivity of air)

.....  
 .....

- f) Write down an expression for  $K_2$  (thermal conductivity of the material from which the boiler is made of) only in terms being introduced above.

g) ..... (in Page 2)

- (4) Figure shows two coils of wire A and B placed coaxially closer to each other in air. Coil A is connected to a centre zero galvanometer and a switch  $S_1$  while coil B is connected to a battery and a switch  $S_2$ .

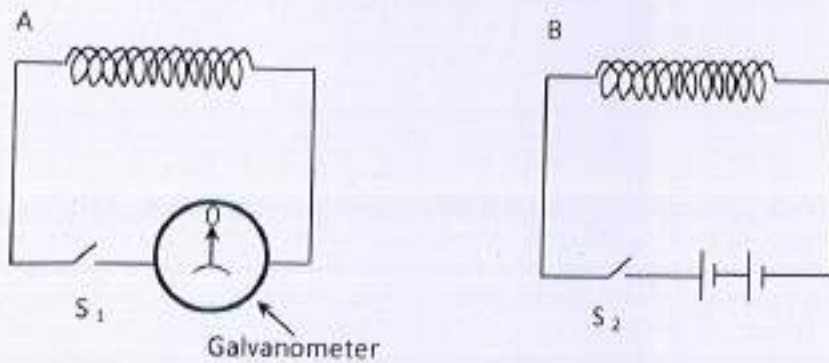

- a) You have to carry out the following experiments independent of each other. Choose and underline the expected reading from the galvanometer for each experiment.

Experiment	Galvanometer reading
(i) First switch $S_1$ is closed; And then switch $S_2$ is opened and closed repeatedly.	a) Zero b) a constant value which is not zero c) keeps changing (oscillates either side)
(ii) First $S_2$ is closed and then $S_1$ is closed	a) Zero b) a constant value which is not zero
(iii) First $S_2$ is closed; and then $S_1$ is closed and opened repeatedly.	a) Zero b) a constant value which is not zero c) keeps changing (oscillates either side)

- b) Battery connected to coil B is now replaced with an alternating potential supply having variable frequency. Now both  $S_1$  and  $S_2$  are closed. Explain giving reasons the variation of the Galvanometer deflection when the frequency of the variable supply becomes.

- (i) 2Hz .....
- .....
- (ii) 2KHz .....
- .....



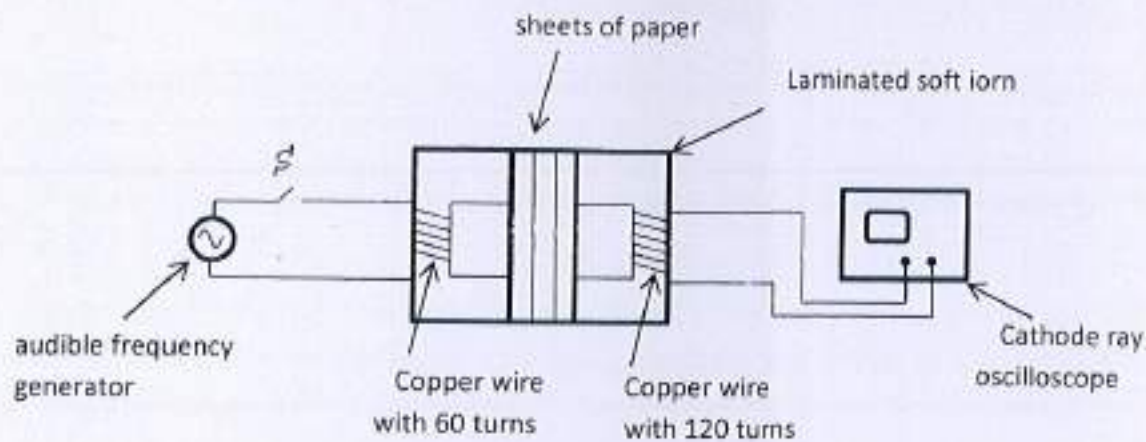

shown

Show here is a circuit arrangement for a transformer. Audible frequency generator is given a sinusoidal input of  $V_{r.m.s} = 7V$ .

- (i) First the papers are removed and the two C shaped laminated soft iron cores are pushed towards each other. Then switch S is closed. Work out the maximum potential difference (+) and (-) (peak to peak voltage difference). Clearly state your assumptions.

.....

.....

.....

.....

.....

- (ii) Now the papers are replaced between the two soft iron cores and a  $100\Omega$  resistor is connected across the CRO. Maximum {(+) and (-)} potential difference is measured from the CRO with the no. of sheets inserted within the 2 soft iron cores.

No. of sheets within the two soft iron cores	(+) and (-) maximum potential difference	Power delivered (W)
1	18	
3	12	

Work out the power delivered to the resistor for each case and complete the table.

.....

.....

.....

.....

.....

(iii) Why soft iron is used as the core of a transformer?

.....  
.....

(iv) Why laminated soft iron plates are used in the core ?

.....

(v) Give 2 reasons for the power loss occurring in a transformer.

.....  
.....



APB

**PART B – Essay**

• Answer any four questions.

(5)

$\left[ \begin{array}{l} \tau \approx 3 \\ \tau^2 \approx 10 \end{array} \right]$

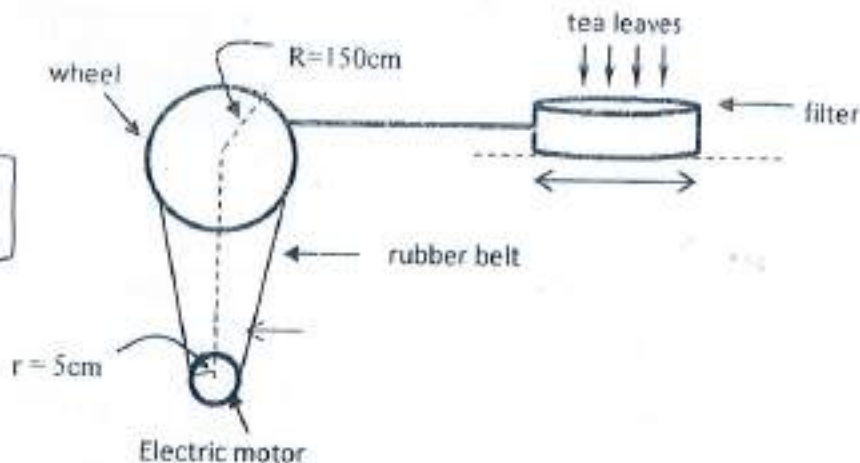

Shown here is a set up used to separate and categorise tea leaves. Tea dust is filtered, when the filter moves side ways (towards left and right continuously) in a horizontal plane, by the rotation of the wheel (of radius 150cm) on a vertical plane about a horizontal axis.

- a) (i) The motor which was rotating at constant rate 2400rpm came to a rest in 40s due to power failure. What is the angular deceleration of the motor?
  - (ii) What is the reason for the motor rotating at a constant angular velocity before the power failure?
  - (iii) What is the power required to rotate the motor at this constant angular velocity?
  - b) (i) What is the tangential speed at the edge (circumference) of the motor, rotating at the above constant rate?
  - (ii) What is the corresponding angular velocity of the wheel?
  - (iii) What is the oscillating frequency of the filter?
  - (iv) What is the oscillating amplitude of the filter?
  - (v) What is the maximum acceleration of the filter?
  - (vi) Sketch the variation of displacement for the oscillations of the filter ( $x$ ) with the resultant force ( $F$ ) acting on it.
- (6) a) (i) State the <sup>sign</sup> ~~sign~~ convention used in the lens formula.
- (ii) A bright object is placed in front of a lens of focal length 10cm, which produces a real image magnified  $\times 5$ . Find the corresponding object distance.
  - (iii) Now (only) the lens is moved 6cm away from the object, while the object and the screen remained at their previous positions. To obtain a real image once again, how far, towards which direction, the screen has to be shifted?

- b) A convex lens and a concave lens, each of focal length 4cm is positioned at 8cm separation. A vertical linear object is placed on the principal axis at 3cm distance from the convex lens. The final image is formed at 'x' distance from the concave lens. Work out x.
- Is the final image a) real or virtual? b) upright or inverted?
  - Obtain the final image after being refracted from both lenses by constructing a ray diagram considering 2 rays coming from the object.
- c) (i) What is the defect of vision suffered by a person wearing spectacles with concave lenses of power 0.5D?
- What is her natural range of vision with out spectacles?
  - Another person wears spectacles having an equal power to a combination of two lenses of powers +2D and -0.5D. What is his defect of vision?
  - Find his range of vision while wearing spectacles.  
(Least distance of distinct vision = 25cm)

- (7) (i) Give meanings of the terms tensile stress and Young's modulus.
- (ii) When determining Young's modulus of a material it is common to use a specimen (wire) which is very long and very thin. Give the reason for this.
- (iii) The graph shown below represents the tension –extension variation for a Copper wire of length 1.2m and cross sectional area  $1.5 \times 10^{-6} \text{m}^2$ . The tension is gradually increased from zero to a maximum value and then reduced back to zero.

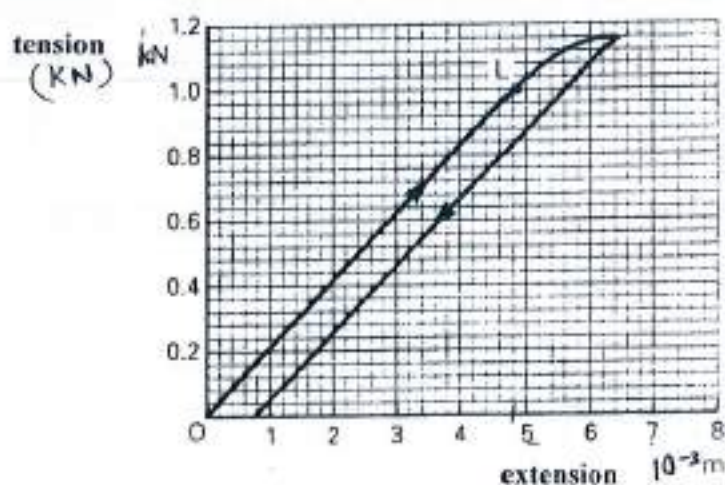

- Use the graph to find the Young's modulus for the material of the wire.
  - Why is the unloading curve displaced from the loading curve?
  - Copy the graph on your answer script and shade the area of the graph which represents the energy lost as heat during the loading and unloading cycle.
- (iv) A 20m length of continuous steel railway line of cross sectional area  $8 \times 10^{-3} \text{m}^2$  is welded into place after heating to a uniform temperature of  $40^\circ\text{C}$ . Take Young's modulus of steel to be  $2 \times 10^{11} \text{Pa}$ . linear expansivity of steel ( $\alpha$ ) =  $12 \times 10^{-6} \text{K}^{-1}$  density of steel =  $7800 \text{kgm}^{-3}$ . Specific heat capacity of steel =  $500 \text{Jkg}^{-1} \text{K}^{-1}$ .



Calculate for normal operating conditions of the railway line at  $15^{\circ}\text{C}$ ;

- the tensile strain
- the tensile stress
- the elastic strain energy in the rail
- How much heat would be required to return the rail to  $40^{\circ}\text{C}$  from  $15^{\circ}\text{C}$ ?
- Explain briefly why your answer is not the same as that of (c).

- (8) A conducting plate can be used <sup>to</sup> store electric charge. But its electric <sup>capacitance</sup> is at a lower value.

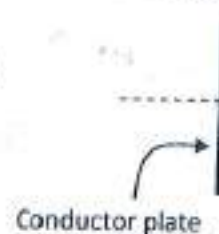

- Copy the conducting plate shown here on to your answer script and show how a positive charge can be distributed on it.
- Now another plate which has been earthed is brought closer to the charged plate. Will this increase or decrease the potential of charged plate? Give reasons for your answer.

- (iii) Copy this diagram on to your answer script and show the distribution of charges on the charged plate in the presence of the earthed plate.

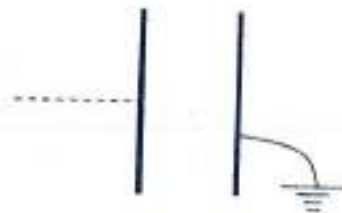

- (iv) Electric capacity of a parallel plate capacitor can be increased by introducing a dielectric material between the plates. What is the main reason for this?

- (v) A cell of e.m.f ( $E$ ) connected to a capacitor ( $C$ ) (Which is not charged at the beginning) is shown here. When the circuit is closed through the switch,  $Q$  charge flows through the cell. Write down expressions for a) energy supplied from the cell b) energy stored in the capacitor, in terms of  $E$  and  $Q$ .

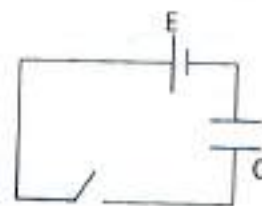

- (vi) A metal plate of area ' $A$ ' is held horizontally by four identical springs each of spring constant  $K$ . Another identical plate is held horizontally below the first plate. The supports from which the springs are suspended are electrically insulated. First plate is under a potential  $V$ .

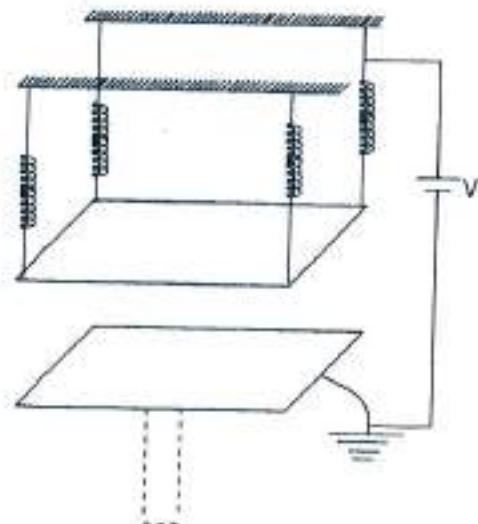

- a) Explain why the separation between the plates decreases, when the potential is increased to  $V$ .
- b) Show that the maximum electrostatic force between the 2 plates  $- F = \frac{QV}{2d}$  where  $d$  - separation between the plates.  
 $Q$ - charge on each plate.
- c) Show that the maximum (additional) extension of each spring, when the plate is being charged  $- e = \frac{\epsilon_0 A V^2}{8kd^2}$ .

(vii) Area of one plate in a parallel plate capacitor (of capacity  $100\text{pF}$ ) is  $100\text{cm}^2$ . The gap between the two plates is completely filled with a material of dielectric constant 5. When a  $50\text{V}$  potential difference is maintained between the two plates:

- a) What is the magnitude of free charge on the plates?
- b) What is the magnitude of electric field intensity across the dielectric material?
- c) What is the magnitude of the induced charge on the surface of the dielectric board? ( $\epsilon_0 = 9 \times 10^{-12} \text{Fm}^{-1}$ )

• Answer either part A or part B.

(9) (A) a) A source of electro motive force ( $X$ ) is connected to a parallel combination of 6 identical bulbs. Internal resistance of  $X$  is  $1\Omega$ .  $0.5\text{A}$  current flows through  $X$ . Potential difference between the terminals of  $X$  is  $120\text{V}$ .

- (i) What is the electromotive force of the source ( $X$ )?
- (ii) What is the power dissipated in  $X$  in the form of heat?
- (iii) What is the total power delivered to the circuit by  $X$ ?
- (iv) What is the total power of the set of bulbs?
- (v) What is the equivalent resistance of the set of bulbs?
- (vi) Assume point  $A$  is earthed. Copy the following axes on your answer script and plot the variation of potential along  $A-B-C-D-E-F-G-A$

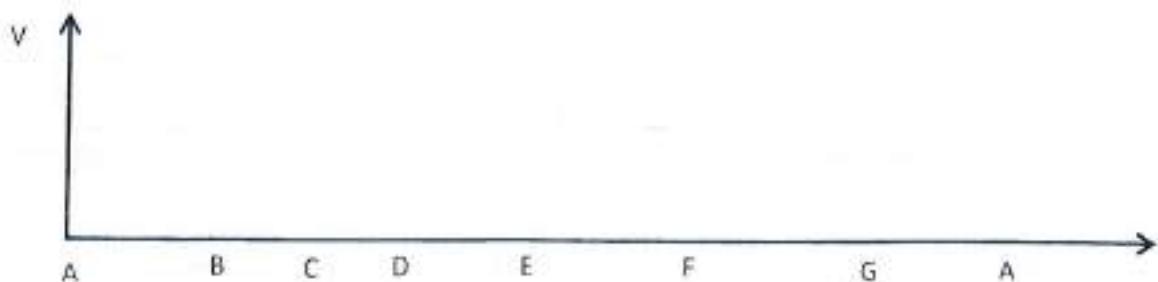
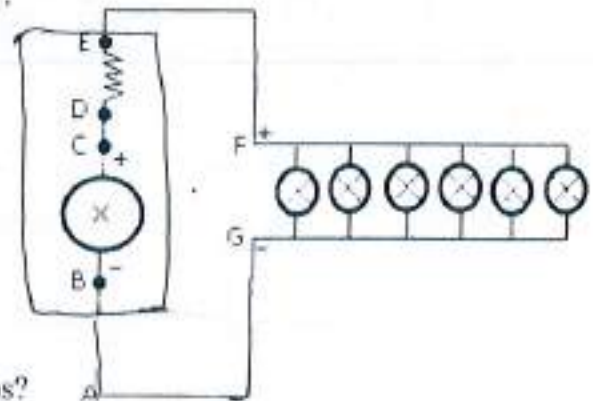



- b) Now the parallel combination of bulbs has been replaced with another six bulbs connected in series across  $\lambda$ . Assume the current through the circuit and the power consumption of the set of bulbs remains the same as above.

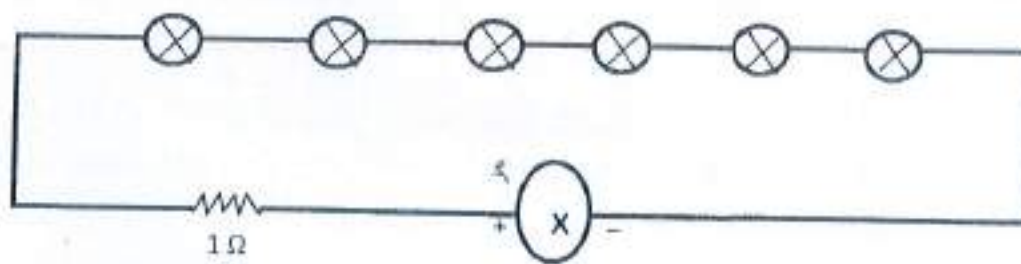

- (i) State a possible disadvantage of using bulbs in series (though the energy consumption remain the same)
  - (ii) What is the power consumption when only one of the bulbs is connected across 120V potential difference? What is the corresponding current through the bulb?
  - (iii) State a possible disadvantage of using these 6 bulbs in a parallel combination.
  - (iv) When one of the six bulbs connected in series is with a broken filament, you can detect the defected bulb, by connecting an ideal voltmeter across each bulb (at 6 different instances) and obtaining the corresponding voltmeter readings. What are the expected readings from the voltmeter when connected across a functioning bulb and the broken bulb?
- (B) (i) A transistor can be biased in 3 configurations, out of which only one is mostly used.
- a) What is that configuration? Explain the reason for this configuration being preferred over the other two.
  - b) Bias a transistor in that preferred configuration using batteries and obtain its\* (voltage / power / current) gains.

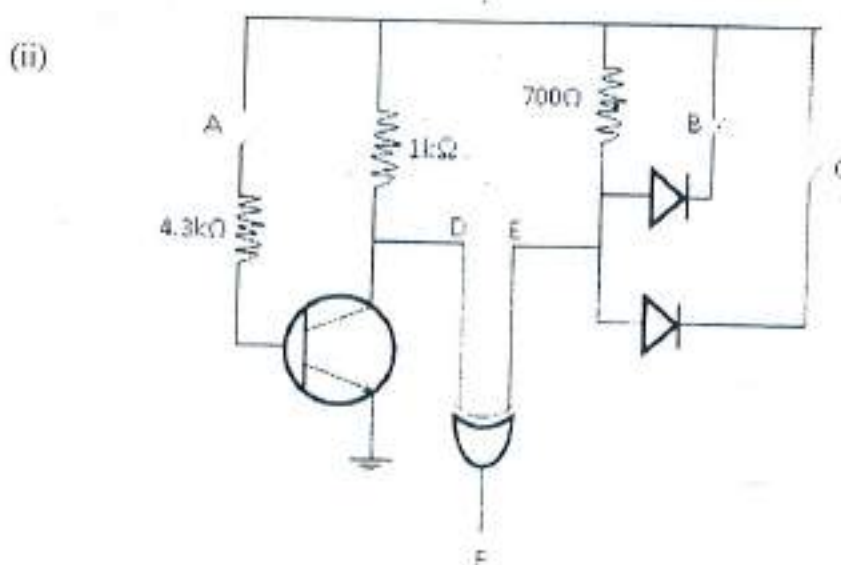

For the npn transistor connected in the circuit here  $V_{BE} = 0.7\text{V}$  and DC voltage gain = 100

- a) Show that the transistor is saturated when switch A is closed.
- b) Find the potential at point D when switch A is open.
- c) What is the potential at point E when switches B and C are closed simultaneously?
- d) The above circuit is used in a modern day machinery. Consider A,B,C, to be inputs. Tabulate all the possible potential states for open and closed states. Mention the potential at F for each state in your table.
- e) Write down the Boolean expression considering the A,B,C inputs and their corresponding F output in your table.

(10) (A) (i) In terms of the kinetic theory of matter explain what is meant by <sup>saturated vapour and</sup> saturated vapour pressure. (S.V.P)

- (ii) Draw sketch graphs showing how the pressure P of  $1\text{m}^3$  of water vapour at  $20^\circ\text{C}$  (with a small amount of water present through out) will vary when;
  - a) the vapour is compressed isothermally to a volume of  $0.2\text{m}^3$ .
  - b) the vapour (and water) are heated at constant volume to the boiling point of water ( $100^\circ\text{C}$ ).

In each case show on your graph the final vapor pressure exerted by the water vapour. (saturated vapour pressure at  $20^\circ\text{C}$  is  $2.4\text{KPa}$ ) atmospheric pressure =  $100\text{KPa}$

- (iii) A vessel contains only water vapour at a temperature of  $360\text{K}$  and pressure  $2.1 \times 10^4 \text{Nm}^{-2}$ . It may be assumed that unsaturated vapour behaves like an ideal gas. S.V.P at  $360\text{K} = 6 \times 10^4 \text{Nm}^{-2}$  S.V.P. at  $300\text{K} = 3 \times 10^3 \text{Nm}^{-2}$ .
  - a) If the vapour were to remain unsaturated what would be the pressure in the vessel at  $300\text{K}$ ?
  - b) What is the actual pressure at this temperature?
  - c) What fraction (if any) of the vapour has condensed at  $300\text{K}$ ?

- (iv) An air conditioning system is required to increase the relative humidity of  $0.5\text{m}^3$  of air per second from 30% to 65%. The air temperature is  $20^\circ\text{C}$ . How many Kg of water are needed by the system per hour?

S.V.P. at  $20^\circ\text{C} = 2.4 \text{KPa}$

$R = 8.31 \text{Jmol}^{-1}\text{K}^{-1}$

Relative molecular mass of water =  $18\text{g}$



(B) Figure shows a modern day X ray tube.

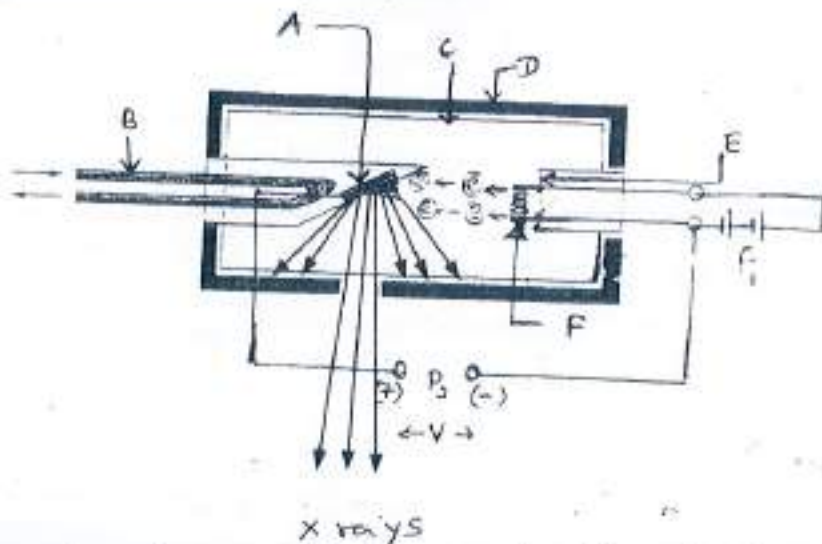

X rays

The maximum frequency of the X rays produced, depend on the potential difference applied across the X-ray tube. When an electron hits A its' energy is not completely lost due to the emission of single X-ray photon. After an electron collides with the atoms of A it loses different fractions of its' energy due to several collisions of the atoms of A, and hence the <sup>electron</sup> decelerates. About 99% of the Kinetic energy <sub>lost is converted to heat energy.</sub> This systematic loss of energy from the electron, produces a continuous spectrum of X-rays with a continuous range of wavelengths.

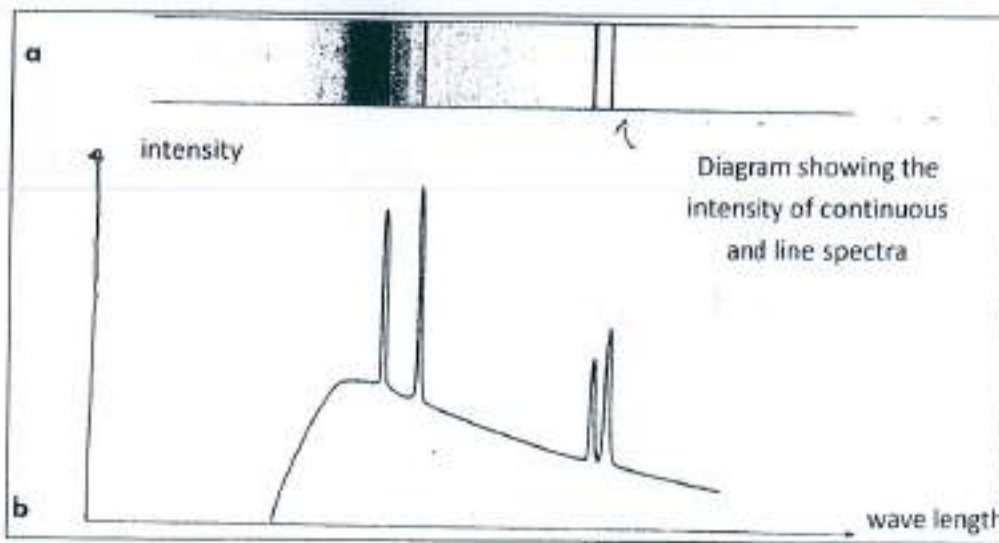

Diagram showing the intensity of continuous and line spectra

The intensity of the spectrum remarkably increases for some narrow wavelength ranges. The following graph shows the variation of intensity with the wavelength of the continuous X ray spectrum. When the potential difference exceeds (or equal to) 25KV a line spectrum corresponding to higher intensities is obtained in addition to the continuous spectrum.

X-ray photons with maximum energy is produced when the total kinetic energy of an electron is completely converted into an X-ray photon. Such X-ray photons are of maximum frequency ( $f_{max}$ ) and of minimum wavelength ( $\lambda_{min}$ ). In the continuous spectrum corresponding to minimum wavelength, the value of  $\lambda_{min}$  depends on  $V$ . Wavelengths corresponding to line spectrums of higher intensity are characteristics of the metal used in A, which does not depend on  $V$ .

- (B) (i) Identify the components A, B, C, D, E, F in the experimental set up.
- (ii) What is the function of B?
- (iii) The apparatus produces a continuous spectrum of X rays in a certain range of energy with a limited maximum value. Explain.
- (iv) What is the requirement to be satisfied to obtain a X ray photon <sup>line</sup>spectrum, in addition to the continuous spectrum? What factor determines the wavelength range corresponding to the line spectrum?
- (v) State the functions of the potential supplies P<sub>1</sub> and P<sub>2</sub>.
- (vi) a) What is the energy of accelerating electrons under potential difference 80KV from P<sub>2</sub> . potential supply? (Planck constant  $6.6 \times 10^{-34}$  Js)
- b) What is the maximum energy of X-ray photons under the above operating potential supply? (Planck constant =  $6.6 \times 10^{-34}$  Js)
- c) What is the maximum frequency of X-ray thus produced?
- d) What is the corresponding wavelength of X-rays?
- (vii) What is the inverse process to X-ray production?
- (viii) A certain radioactive sample contained  $8.46 \times 10^3$  radioactive nuclei when its' activity showed  $1.85 \times 10^5$  Bq. Work out its'
- a) decay constant
- b) half life ( $T_{\frac{1}{2}} = \frac{0.693}{\lambda}$ )
- c) time taken to bring down its' activity to  $1.156 \times 10^4$  Bq

charge of an electron =  $1.6 \times 10^{-19}$  C.  
 speed of light =  $3 \times 10^8$  ms<sup>-1</sup>



# Answers to MCA.

Grade 13 - July 2015 - final Term Test

1) 1	11) 5	21) 4	31) 5	41) 2
2) 3	12) 4	22) 2	32) 5	42) 5
3) 5	13) 5	23) all	33) 4	43) 5
4) 3	14) 4	24) 4	34) 1	44) 3
5) 5	15) 2	25) 4	35) 4	45) all
6) 3	16) 4	26) 5	36) 1	46) 1
7) 1	17) 4	27) 5	37) 3	47) 4
8) 2	18) 4	28) 2	38) 5	48) 3
9) 3	19) 1	29) 2	39) 3	49) 2
10) 5	20) 3	30) 4	40) 3	50) 2

# Grade 13 - Final Term Test

June - 2015

PHYSICS - Part II

## Part A - Structured Essay

① a) i)  $V = r\omega$        $V_{\max} = A\omega$        $k$  - spring constant

$T = 2\pi\sqrt{\frac{M}{k}}$  ← for the simple harmonic oscillations of a helical spring       $T = 2\pi/\omega$        $\omega = \sqrt{\frac{k}{M}}$

$V_1 = A\omega$        $V_1 = A\sqrt{k/M}$        $M$  - mass performing simple harmonic motion

ii) Applying the conservation of linear momentum as there are no external forces acting on the system when  $m$  placed on  $M$ ;

$$(M+m)V_2 = M V_1 \quad V_2 = \frac{M V_1}{M+m}$$

iii)  $V = A\omega$        $V_2 = A_2\omega_2$        $\omega_2 = \sqrt{\frac{k}{(M+m)}}$  ← total mass performing s.H.M.

$$V_2 = \frac{M V_1}{M+m} \quad A_2 = \frac{V_2}{\omega_2}$$

$$A_2 = \frac{M V_1}{(M+m)} \times \sqrt{\frac{M+m}{k}} = \frac{M V_1}{\sqrt{(M+m)k}}$$

$$A_2 = \frac{M \times A \sqrt{k/M}}{\sqrt{(M+m)k}} = \sqrt{\frac{M}{M+m}} \times A$$

iv) Yes. Because the amplitude of oscillations has decreased.  $A_2 < A$       →  $\sqrt{M/(M+m)} < 1$  OR

Work is done against friction when  $m$  slides on  $M$  for a very shorter period of time before coming to rest relative to  $M$ .



$$b) i) mgx = \frac{1}{2} kx^2 + Fx$$

$mgx$  = decrease in potential energy of  $m$

$\frac{1}{2} kx^2$  = elastic potential energy stored in the spring

$Fx$  = Work done against friction ( $F_k$ )

$F_k = \mu_k R$      $R = Mg$      $F_k$  - Kinetic frictional force

$$F_k = \mu_k Mg$$

$$mgx = \frac{1}{2} kx^2 + \mu_k Mg x$$

$$ii) mg = \frac{1}{2} kx + \mu_k Mg$$

$$\frac{1}{2} kx = mg - \mu_k Mg$$

$$x = \frac{2mg}{k} - \frac{2\mu_k Mg}{k}$$

$$x = \frac{2g}{k} \cdot m - \frac{2\mu_k Mg}{k}$$

$$\downarrow \quad \downarrow$$

$$y = m \quad x = c$$

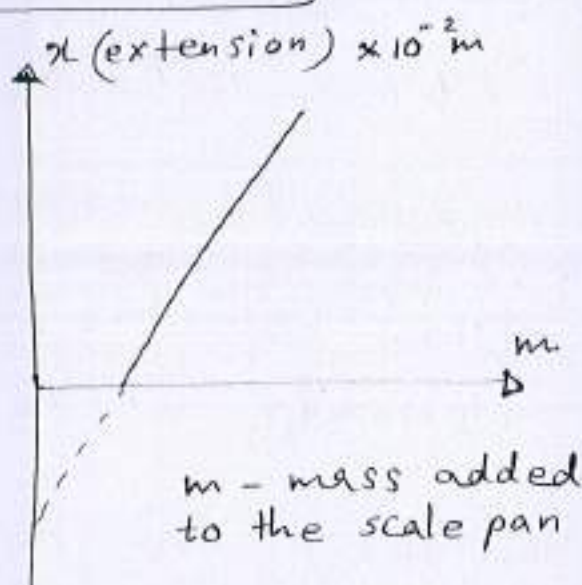

iii) Plotting the graph - (a)

iv) gradient =  $26/15 \text{ m kg}^{-1}$      $(1.6 - 1.8) \text{ m kg}^{-1}$

v) Intercept :  $103 \times 10^{-2} \text{ m}$

$$vi) \frac{m}{c} = \frac{\text{gradient}}{\text{intercept}} = \frac{2g/k}{2g/k \times \mu_k M} = \frac{1}{\mu_k \times 0.7}$$

$$\frac{c}{m} = \frac{103 \times 10^{-2}}{26/15} = \mu_k \times 0.7 \quad \mu_k = \underline{\underline{0.84}}$$

one mark for each part.  $0.1 \times 10 = 1.0$

(2) i) The intensity of sound produced solely by vibrating a wire is very less.

When the vibrating wire is in connection with the hollow wooden box, the air inside the box vibrates along with the wire.  $\therefore$  the sound is amplified - an intensified sound is heard.

ii) Attach a mass at the free end of the wire. Bring the movable knife edge as closer as possible with the fixed knife edge, and set the vibrating length to a minimum. Place a small paper rider in the middle of the vibrating segment of the wire.

Vibrate the tuning fork and place it gently on the sonometer box, closer to the segment of string between the knife edges. Slowly shift the movable peg away from the fixed one and obtain the length of the string when the paper riders fall off the wire. Repeat the above procedure for different weights.

$$iii) f = \frac{1}{2l} \sqrt{\frac{Mg}{m}}$$



$$\lambda = 2l$$

$$T = Mg$$

$$v = \sqrt{T/m}$$

$$f = \frac{v}{\lambda}$$

$$iv) l = \frac{1}{2f} \times \sqrt{\frac{g}{m}} \times \sqrt{M}$$

$$l = k \sqrt{M}$$

$$y = m x$$

$$g = 10 \text{ ms}^{-2}$$

$$f = 512 \text{ Hz}$$

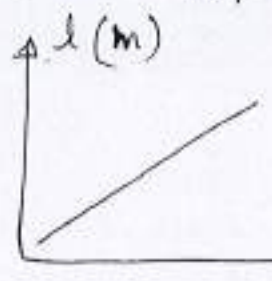

$l$  - resonance length

$M$  - mass at the end of the wire

$$\text{gradient} = \frac{1}{2f} \sqrt{\frac{g}{m}} = \frac{5}{64} \text{ m}/\sqrt{\text{kg}}$$

$$\frac{5 \times 5}{64 \times 64} = \frac{1}{4 \times f^2} \times \frac{g}{m}$$

$$m = \frac{64 \times 64 \times 10}{25 \times 4 \times 512 \times 512}$$

$$m = 1.56 \times 10^{-3} \text{ kg m}^{-1}$$



v)  $m = A\rho$      $A = \pi r^2$      $r = d/2$      $A = \frac{\pi d^2}{4}$   
 $\rho = m/A$  to find the area of cross section of the sonometer string: diameter of the string is to be read from micrometer screw gauge  
 (area or radius is not a reading as they cannot be measured directly from any measuring instrument)

vi)  $\rho = \frac{m}{\pi d^2/4}$      $\rho = 4m/\pi d^2$   
 where,  $\rho$  - density of the string material  
 $m$  - linear density of the string material

vii) linear density varies depending on the diameter or density of strings, which enables the production of notes with different frequencies within equal lengths of different strings in the set.

- ② i) - 01    ii) 02    iii) 01    iv) 02    v) 02  
 vi) 01    vii) 01.

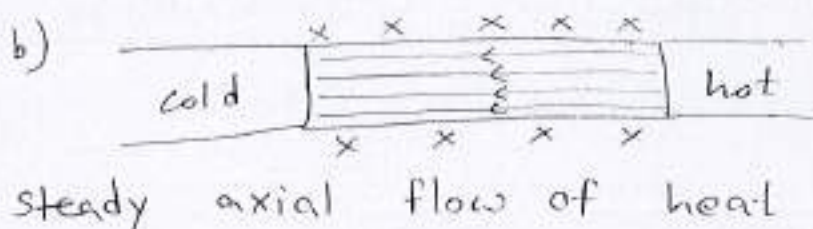
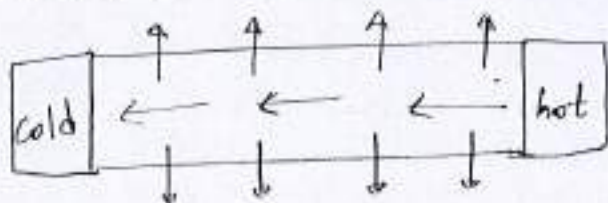
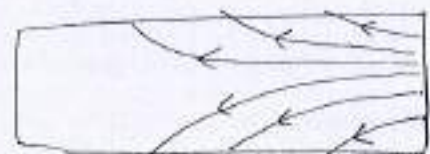
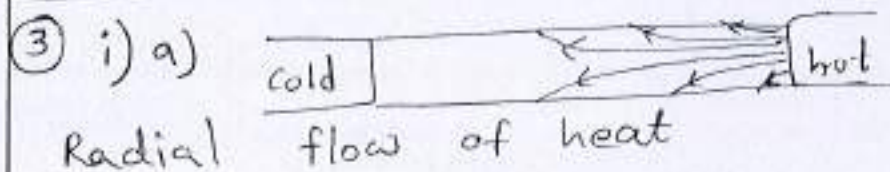

- 3) i) a) 01  
 b) 01  
 ii) 01    f)  $1\frac{1}{2}$   
 b) 01    g) 01  
 c) 01  
 d) 01  
 e)  $1\frac{1}{2}$

ii) Layer of air is a thermal insulator.  $\therefore$  Low thermal conductivity.  $\frac{Q}{t} = kA \frac{\Delta\theta}{\Delta l}$

Rate of heat flow  $\frac{Q}{t}$  through the layer of air and through the wall of the boiler are the same during the steady state.

Efficient thermal conduction reduces the temperature gradient.

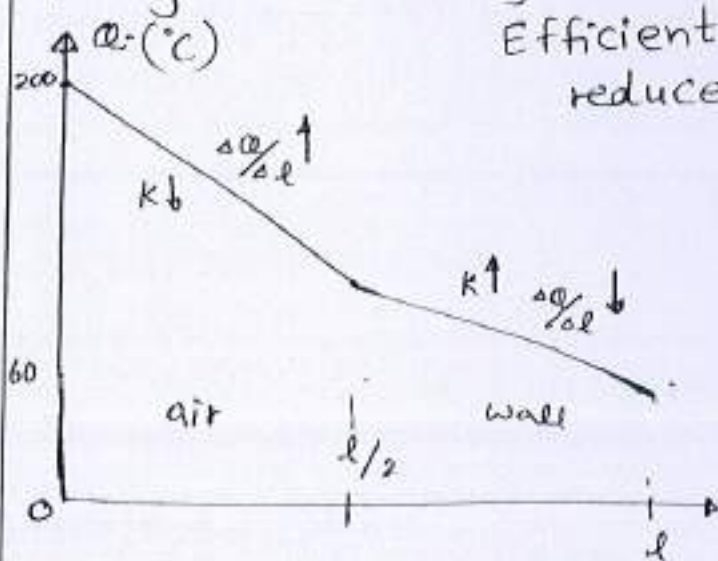

b) That is when the rate of heat absorption by water from the flames becomes equal to the rate of heat loss to the surrounding.

$$c) \frac{dQ}{dt} = ms \frac{\Delta\theta}{dt} = 2 \times 4000 \times \frac{(60 - 30)}{(5 \times 60)}$$

$$s = 4000 \text{ J kg}^{-1} \text{ K}^{-1} \quad m = 2 \text{ kg} \quad \Delta\theta = \theta_2 - \theta_1 = 60^\circ\text{C} - 30^\circ\text{C}$$

$$t = 5 \text{ min} \times 60 = 300 \text{ s}$$

$$\frac{dQ}{dt} = \underline{\underline{800 \text{ W}}}$$

d) 800W (it is the same according to the explanation given in b) above.

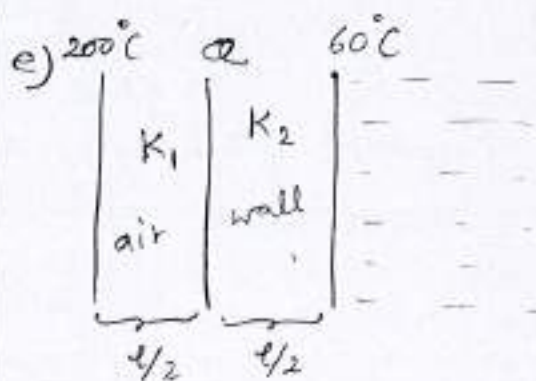

$$\frac{Q}{t} = kA \frac{\Delta\theta}{\Delta l}$$

$$800 = k_1 A \frac{(200 - \theta)}{l/2}$$

$$400 = k_2 A \frac{(200 - \theta)}{l}$$



$$f) \frac{Q}{t} = K A \frac{\Delta \theta}{\Delta l}$$

from e) above

$$400 = \frac{K_1 A}{l} (200 - \theta)$$

$$800 = K_2 A \frac{(\theta - 60)}{l/2}$$

$$\theta = 200 - \frac{400 l}{K_1 A}$$

$$400 = K_2 A (\theta - 60)$$

$$400 = K_2 A \left\{ \left( 200 - \frac{400 l}{K_1 A} \right) - 60 \right\}$$

$$K_2 = \frac{400 l}{A \left( 140 - \frac{400 l}{K_1 A} \right)}$$

$$g) \theta_R = 30^\circ C \quad \frac{dQ}{dt} \propto (\theta - \theta_R) \quad \frac{dQ}{dt} = K A (\theta - \theta_R)$$

$(\theta - \theta_R)$  = excess temperature  
 rate of heat loss to the surrounding =  
 rate of heat supply by the flames

$$\text{When } \theta = 60^\circ C \quad Q/t = 800 \text{ W}$$

$$\text{When } \theta = 70^\circ C \quad Q/t = H$$

$$800 = K A (60 - 30)$$

$$\frac{800}{H} = \frac{30}{40}$$

$$H = \frac{3200}{3} \text{ W}$$

$$H = \underline{\underline{1066.67 \text{ W}}}$$

$$H = K A (70 - 30)$$

④ a) i) When  $S_1$  closed, there is a closed path for the induced current to flow through the galvanometer. When  $S_2$  is opened and closed continuously, the magnetic flux associated with coil B changes alternatively, which induces a current through A.

c) keeps changing - oscillates either side

ii) The preliminary requirement to induce a current is to have magnetic flux associated with the coil change with time. When  $S_2$  remains closed



there is no magnetic flux change associated.  
 $\therefore$  no induced current through (G). ii - zero

iii) Closing and opening  $S_1$  doesn't change the magnetic flux associated with B.  $\therefore$  no induced current through (G). The change of magnetic flux is due to the change in current supply to B, which in turn induces a current through A. iii) zero

{if all 3 correct 01 mark }

b) (G) deflects at the same frequency of the alternating potential supply.

i) 2 Hz - the indicator of (G) oscillates either side about 0 mark at 2 Hz. i.e. it takes 0.5s to complete one oscillation. therefore the (G) deflections are noticed by the human eye.

ii) 2 kHz - the indicator oscillates at a rate 2000 Hz i.e. one oscillation takes only  $\frac{1}{2 \times 10^3} \text{ s} = 0.5 \text{ ms}$  the indicator oscillates very quickly that you can't recognize its' deflections.  $\therefore$  We notice this rapid fluctuation of (G) reading as if it shows no deflection. i.e. (G) reads zero

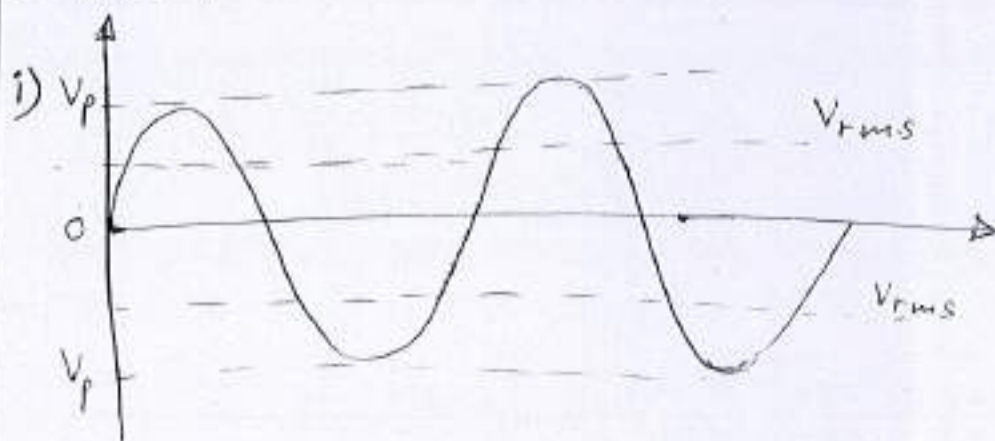

19.796 V  $\leftarrow$  peak to peak voltage difference for primary coil AC input

$$V_p = \sqrt{2} V_{rms}$$

$$V_p = 7\sqrt{2} \text{ V}$$

Peak to peak voltage difference

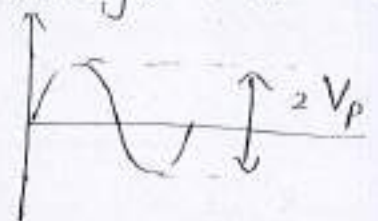

$$2 V_p = 2 \times 7\sqrt{2} \text{ V} = 14\sqrt{2} \text{ V}$$

$$14 \times 1.414 \text{ V} = 19.796 \text{ V} \quad [7]$$



Assumptions: An ideal transformer  
 It amplifies the input AC voltage without any loss of power.

$$\frac{V_s}{V_p} = \frac{N_s}{N_p} = \frac{120}{60} = 2$$

$V_s = 2V_p$  - A step up transformer

7V is the  $V_{rms}$  input (AC) for the primary coil.  
 for the secondary coil  $V_{rms}$  output =  $2 \times 7V = 14V$

$V_{peak}$  for the secondary coil =  $14\sqrt{2}V$   
 peak to peak voltage for the secondary coil:

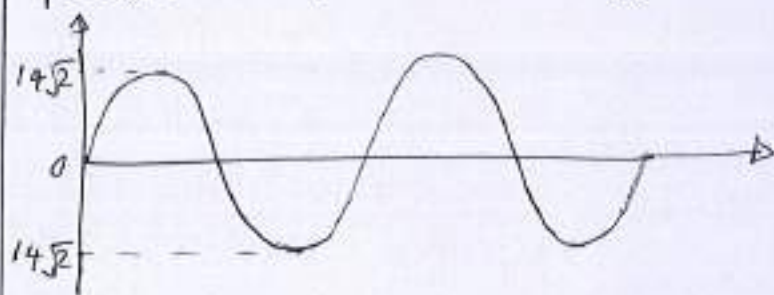

$$2 \times 14\sqrt{2} = 2 \times 19.796$$

$$2 \times V_{peak\ to\ peak\ in\ the\ primary\ coil} = \underline{\underline{39.6V}}$$

ii)  $V = IR$   
 $P = VI$

Power delivered to the resistor =  $V_{rms} \times I_{rms}$  ← from the secondary coil

$$V_{rms} = \frac{V_p}{\sqrt{2}}$$

$$\frac{V_p}{\sqrt{2}} \times \frac{I_p}{\sqrt{2}} = \frac{V_p I_p}{2} = \text{Power delivered to the resistor}$$

$$I_{rms} = \frac{I_p}{\sqrt{2}}$$

$$I_p = \frac{V_p}{R} = \frac{9}{100} A$$

① sheet →  $V_p = 18/2 = 9V$

$$\frac{V_p I_p}{2} = P = \frac{9 \times 9/100}{2} = \frac{0.81}{2} = 0.405W = \underline{\underline{0.41W}}$$

③ sheets →  $V_p = 6/2 = 6V$       $I_p = \frac{V_p}{R} = \frac{6}{100} A$

$$\frac{V_p I_p}{2} = P = \frac{6 \times 6/100}{2} = \frac{0.36}{2} = \underline{\underline{0.18W}}$$

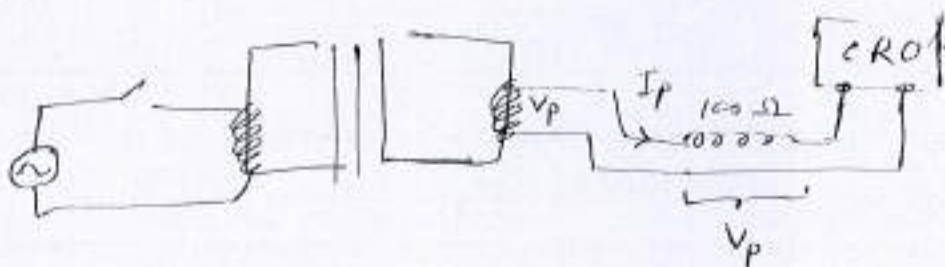

iii) Soft iron is a readily magnetising material. It reduces flux leakage (increases flux linkage) between the primary and the secondary.

iv) To prevent the occurrence of eddy currents within the soft iron core and thereby minimize the power loss through the transformer

v) Joule Heating ( $I^2R$ ) - due to the resistance of the primary and secondary coils of the transformer

Power loss by the heating of the soft iron core due to eddy currents

Flux leakage / Low flux linkage

Hysteresis loss

- ④ a) if all 3 correct - 01      b) i) 01      ii) 01  
 c) i) 02      ii) 02      iii) 01      iv) 01      v) 01 + for any 2 reasons

### Part B - Essay

⑤ a) i)  $\omega_0 = 2\pi f = 2\pi \times \frac{2400}{60} = 80\pi \text{ rads}^{-1}$

$\omega = \omega_0 + \alpha t$

$0 = (80\pi) + 40\alpha$

$\alpha = -2\pi \text{ rads}^{-1}$

if  $\pi = 3.14$

$\alpha = -6.28 \text{ rads}^{-1}$

ii) rotational torque = frictional torque (no resultant torque acting on the rotating system)

iii)  $\tau = I\alpha$        $P = \tau\omega$

$P = I\alpha\omega = I \times 6.28 \times 80\pi$

$P = I \times 2\pi \times 80\pi$        $P = 160\pi^2 I$

if  $\pi^2 \approx 10$

$P = 1600 I \text{ W}$



b) i)  $V = r\omega = 5 \times 10^{-2} \text{ m} \times 80\pi = 4\pi \text{ ms}^{-1}$

ii) Wheel and the motor is connected by the rubber belt: The speed of the belt is the tangential speed of both the rotating wheel and motor.  $\omega = v/r$  wheel and motor has different angular velocities as their radii differ, despite tangential speeds ( $v$ ) being the same.



$$V = r\omega$$

$$4\pi \text{ ms}^{-1} = 150 \times 10^{-2} \text{ m} \times \omega$$

$$\omega = \frac{4\pi}{1.5} = \frac{40\pi}{15} = \frac{8\pi}{3} \text{ rads}^{-1}$$

iii) Filter is directly connected to the wheel.  $\therefore \omega$  and  $f$  for the filter is the same as those of the wheel.

$$\omega = 2\pi f$$

$$f = \frac{\omega}{2\pi} = \frac{8\pi/3}{2\pi} = \frac{4}{3} = 1.33 \text{ Hz}$$

iv) As the wheel rotates the connecting horizontal rod moves back and forth, pulling the filter side ways along with it.  $\therefore$  the oscillating amplitude of the filter is equal to the radius of the wheel:  $1.5 \text{ m}$  //  $(2R = 2A \quad R = A)$

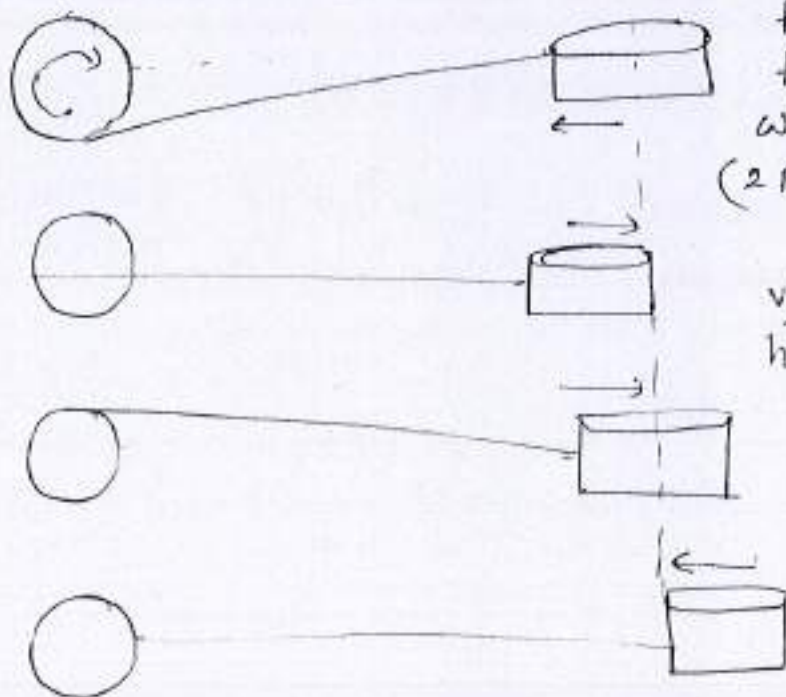

v) for the simple harmonic motion of the filter:

$$a = -\omega^2 x$$

$$a_{\text{max}} = -\omega^2 A$$

$$= (-) \left(\frac{8\pi}{3}\right)^2 \times 1.5$$

$$a_{\text{max}} \approx 96 \text{ ms}^{-2}$$

vi)  $F = -Kx$  Restoring force on a particle performing simple harmonic motion (F) is oppositely directed to the displacement (x).

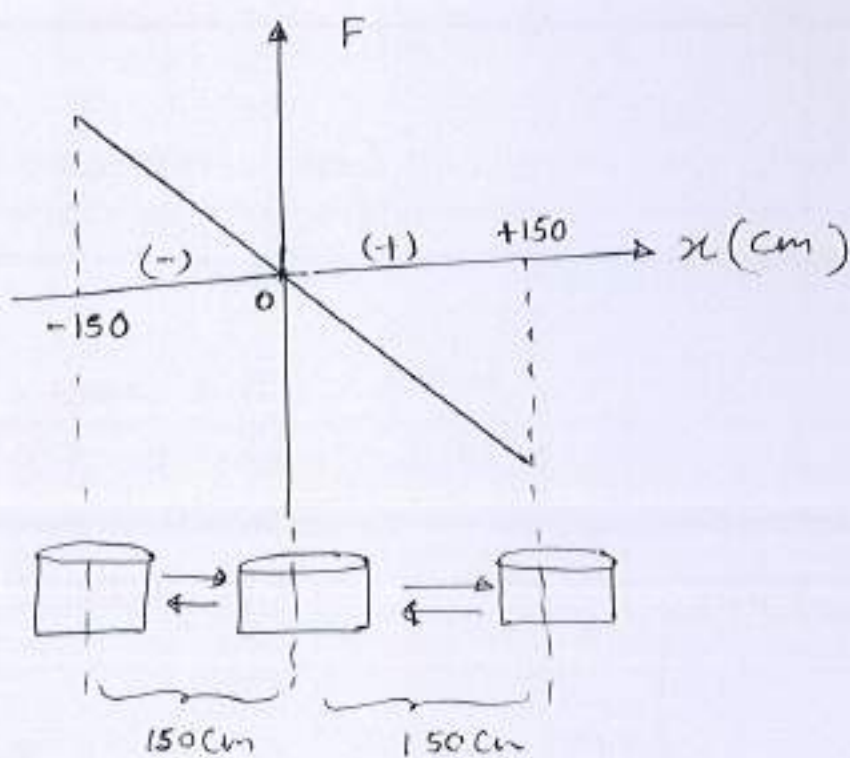

- s) a) i) 0 2  
 ii) 0 1  
 iii) 0 3  
 b) i) 0 1  
 ii) 0 2  
 iii) 0 2  
 iv) 0 1  
 v) 0 2  
 vi) 0 1

6) a) i) All the distances are measured from the optical centre of the lens along the principal axis. Distances measured along the direction of light rays are considered negative (-) and those measured opposite to the light rays are +ve.

ii)  $M = \frac{H_i}{H_o} = \frac{V}{u} = 5$   $V = 5u$   $H_i$  - height of image  
 $H_o$  - height of object

$$\frac{1}{v} - \frac{1}{u} = \frac{1}{f}$$

It should be a convex lens to produce a real image.  $v (-)$   
 for real images:

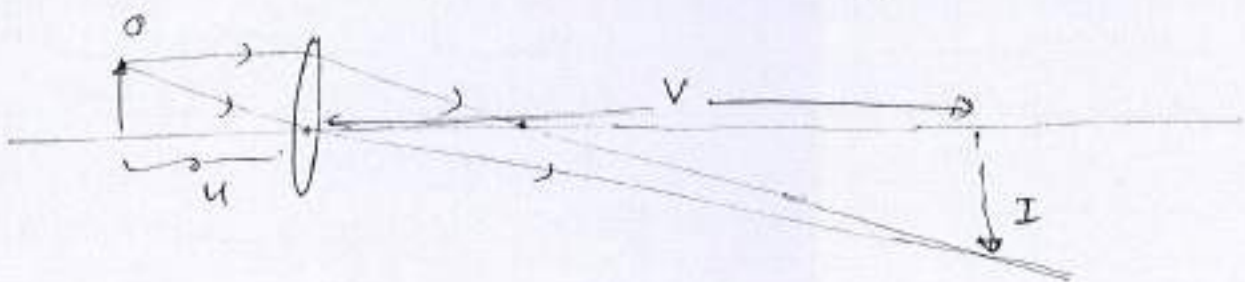



$$\frac{1}{-5u} - \frac{1}{u} = \frac{1}{-f} = \frac{1}{-10}$$

$$\frac{-1-5}{5u} = \frac{-6}{5u} = \frac{1}{10}$$

$$u = +12 \text{ cm}$$

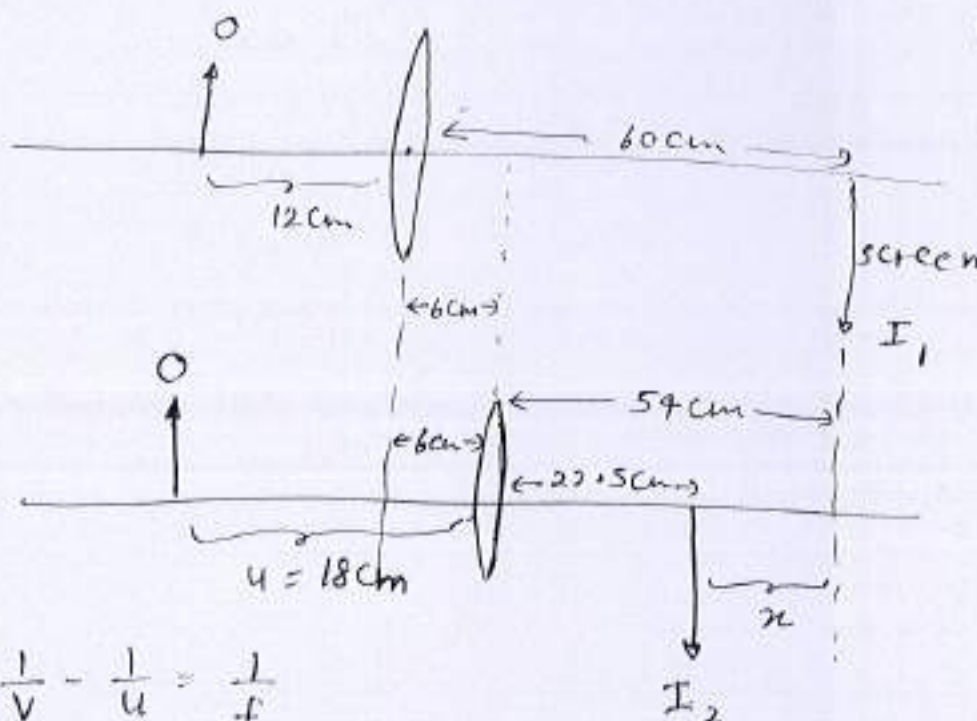

Real images are projected onto screens.

The screen has to be shifted 31.5 cm towards the lens.

$$\text{iii) } \frac{1}{v} - \frac{1}{u} = \frac{1}{f}$$

$$\frac{1}{v} - \frac{1}{18} = \frac{1}{-10}$$

$$v = 22.5 \text{ cm}$$

$$x = 54 - 22.5 = 31.5 \text{ cm}$$

b) i)

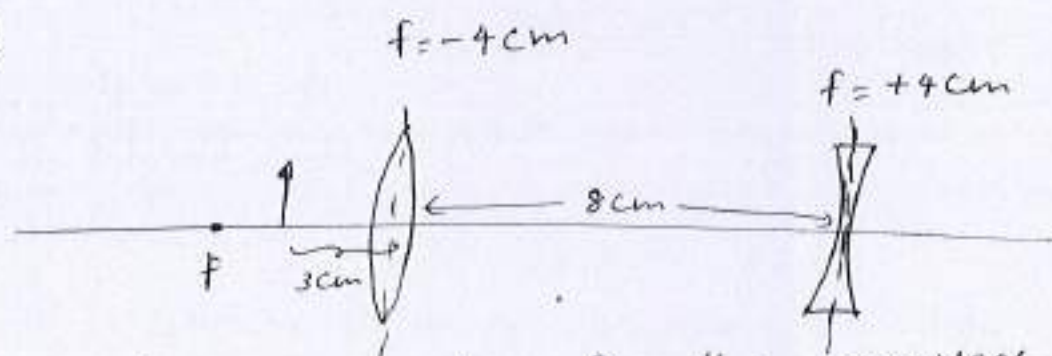

Applying lens formula for the convex lens:

$$u = +3 \text{ cm} \quad f = -4 \text{ cm}$$

$$\frac{1}{v} - \frac{1}{u} = \frac{1}{f}$$

$$\frac{1}{v} - \frac{1}{3} = \frac{1}{-4}$$

$$v = +12 \text{ cm}$$

for the concave lens

$$u = 12 + 8 = +20 \text{ cm}$$

$$f = +4 \text{ cm}$$

$$v = \frac{20}{6} \text{ cm} = +3.33 \text{ cm}$$

$$\frac{1}{v} - \frac{1}{u} = \frac{1}{f}$$

$$\frac{1}{v} - \frac{1}{20} = \frac{1}{4}$$

$M_{\text{convex}} = \frac{v}{u} = \frac{12}{3} = +4$  ← image formed by the convex lens is magnified  $\times 4$  virtual and upright

$M_{\text{concave}} = \frac{v}{u} = \frac{+20/6}{20} = \frac{+1}{6}$  ← diminished virtual upright

Total magnification:  $4 \times \frac{1}{6} = \frac{+2}{3}$

+ sign of magnification denotes the image is virtual and upright.

(-) sign: real, inverted image

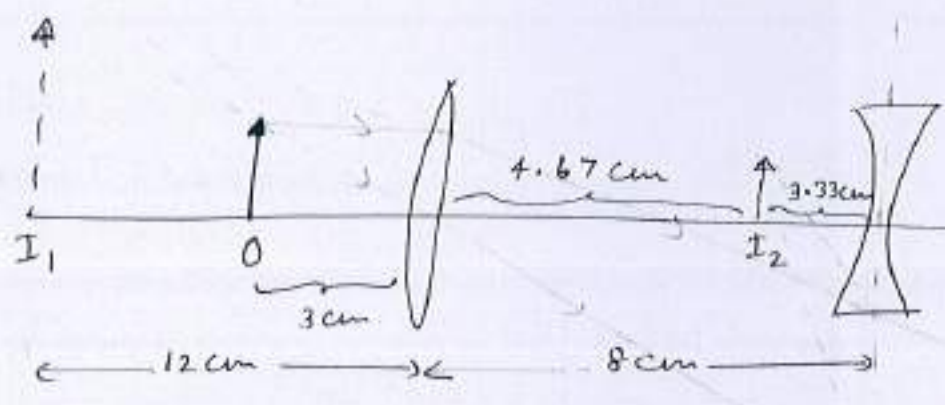

c) i) shortsightedness

ii)  $\frac{1}{f} = 0.5$   $f = 2 \text{ m (+)}$

The spectacles form the images of objects at infinity at the far point of the short sighted eye.  $u = \infty$   $v \leftarrow$  far point  $v = 2 \text{ m}$

$\frac{1}{v} - \frac{1}{u} = \frac{1}{f}$   $\frac{1}{v} - \frac{1}{\infty} = \frac{1}{2}$

assuming her near point is as the same as a normal eye: range of vision without spectacles: 25 cm - 200 cm

iii)  $P = P_1 + P_2 = +2 \text{ D} - 0.5 \text{ D} = +1.5 \text{ D}$  ← convex lenses

iv) long sightedness  $f = \frac{-1}{1.5} = -\frac{2}{3} \text{ m} = -66.67 \text{ cm}$

Wearing spectacles reduces the range of vision. i.e. the far point is brought closer from infinity. objects at 66.67 cm from spectacles form their image at infinity.

$\frac{1}{v} - \frac{1}{u} = \frac{1}{f}$   $\frac{1}{\infty} - \frac{1}{x} = \frac{-3}{200}$   
 $x = 66.67 \text{ cm}$  range of vision with 66.67 cm to spectacles: 25 cm



- 6) a) i) 01    ii) 02    iii) 03  
 b) i) 02    ii) 02    iii) 01  
 c) i) 01    ii) 01    iii) 01    iv) 01

⑦ i) tensile stress: force on a unit area ( $F/A$ )  
 Young's modulus: Ratio between the tensile stress and tensile strain within the proportional limit

$$Y = \frac{F/A}{e/l}$$

ii)  $e = Fl/YA$  when  $l \uparrow$   $A \downarrow$   $e \uparrow$   $\therefore$  a considerable extension is obtained. Fractional error in measuring extension is less.

iii) a)  $Y = \frac{Fl}{eA} = \frac{1.2 \times 10^3 \text{ N} \times 1.2 \text{ m}}{4.8 \times 10^{-3} \text{ m} \times 1.5 \times 10^{-6} \text{ m}^2} = 1.67 \times 10^{11} \text{ Nm}^{-2}$

b) the wire gets a permanent deformation. (when the tension of the wire is no longer there, i.e.  $t=0$ ) a permanent extension 0.8 mm is there.

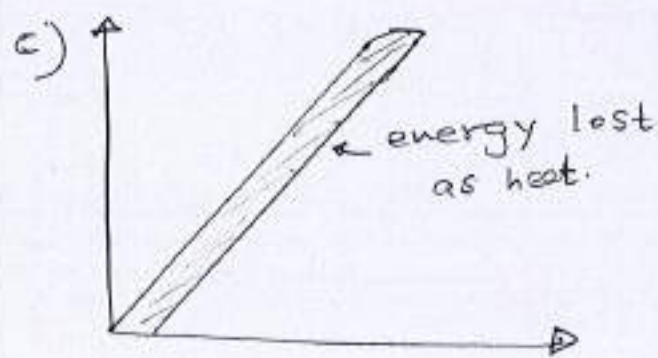

iv)  $\Delta l = l_0 \alpha \Delta \theta = e$

a)  $e = 20 \text{ m} \times 12 \times 10^{-6} \text{ K}^{-1} \times 4 \Delta \theta$   
 $\Delta \theta = 40^\circ \text{C} - 15^\circ \text{C} = 25^\circ \text{C}$   
 $e = 6 \times 10^{-3} \text{ m}$

tensile strain =  $e/l$   
 $= \frac{6 \times 10^{-3}}{20} = 3 \times 10^{-4}$

b)  $\frac{F}{A} = Y \frac{e}{l}$      $\frac{F}{A} = 2 \times 10^{11} \text{ Nm}^{-2} \times 3 \times 10^{-4} = 6 \times 10^7 \text{ Pa}$

c)  $E = \frac{1}{2} Fe$   
 $F = 6 \times 10^7 \times A = 6 \times 10^7 \times 8 \times 10^{-3} \text{ m}^2$   
 $= 48 \times 10^4 \text{ N}$

$E = \frac{1}{2} \times 48 \times 10^4 \times 6 \times 10^{-3}$

$E = \underline{\underline{1.44 \text{ kJ}}}$



$$d) Q = ms\Delta\theta = 1248 \text{ kg} \times 500 \text{ J kg}^{-1} \text{ K}^{-1} \times 25^\circ\text{C}$$

$$m = V\rho = Ah\rho = 8 \times 10^{-3} \text{ m}^2 \times 20 \text{ m} \times 7800 \text{ kg m}^{-3}$$

$$\text{mass of the steel rail} = 1248 \text{ kg}$$

$$s = 500 \text{ J kg}^{-1} \text{ K}^{-1} \quad \Delta\theta = 40^\circ\text{C} - 15^\circ\text{C} = 25^\circ\text{C}$$

$$Q = 1.56 \times 10^7 \text{ J} = 15600 \text{ kJ} = 15.6 \text{ MJ}$$

e) elastic strain in the rails is less than the heat energy required to increase its temperature back to  $40^\circ\text{C}$ . When a rod is under tension, part of the energy is stored in the form of elastic potential energy, and the rest is lost to the surrounding in the form of heat.

- 7) i) 02    ii) 01    iii) a) 02    b) 01    c) 01  
 iv) a) 02    b) 02    c) 02    d) 01    e) 01

10) A) i) Saturated vapour: When a vapour is in dynamic equilibrium with its liquid in a closed container, it is a saturated vapour.

Saturated vapour pressure: When a liquid is in dynamic equilibrium with its own vapour, the pressure exerted by the vapour is its saturated vapour pressure. (SVP)

ii) Vapour remains saturated through out. SVP doesn't change with volume. It only changes with temperature. As long as temperature remains constant SVP remains the same.

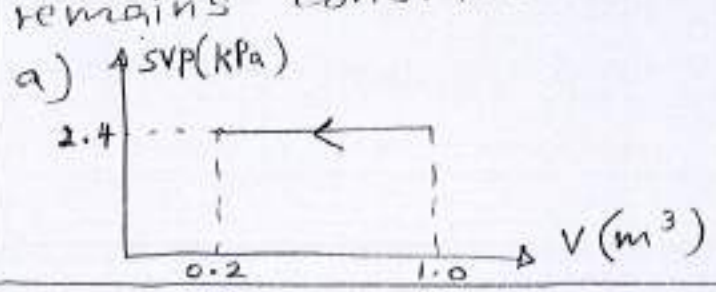



b) SV (saturated vapour) doesn't obey gas laws. SVP increases with temperature but in a different manner to that of an ideal gas.

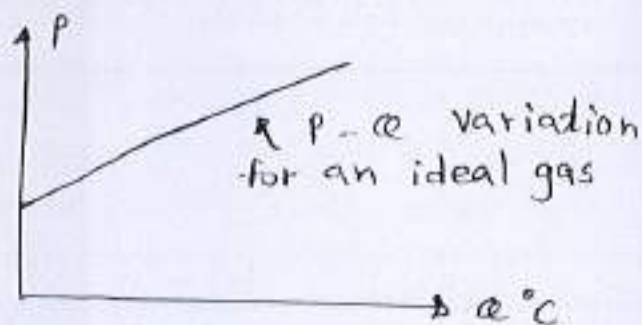
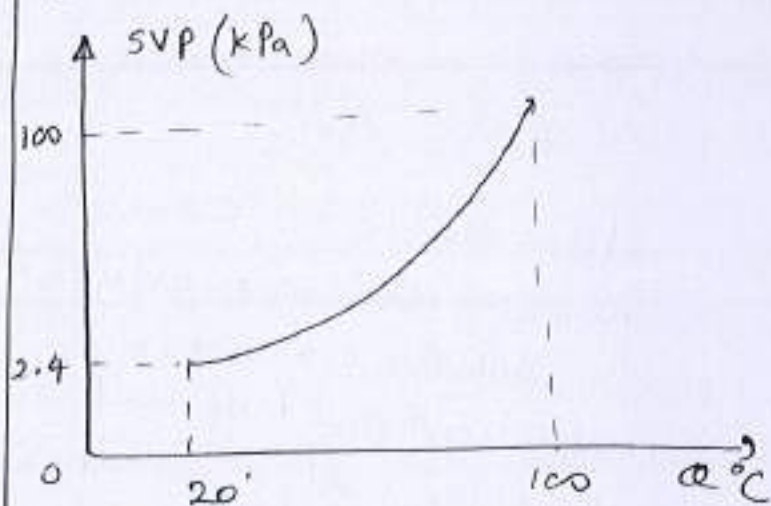

$$\text{iii) a) } \frac{P}{T} = K \quad \frac{P_1}{T_1} = \frac{P_2}{T_2} \quad \frac{2.1 \times 10^4 \text{ Pa}}{360 \text{ K}} = \frac{P_2}{300 \text{ K}}$$

Vapour is unsaturated at 360K temperature as it is not in dynamic equilibrium with its liquid.

$$P_2 = 1.75 \times 10^4 \text{ Nm}^{-2}$$

b) SVP at 300K =  $3 \times 10^3 \text{ Nm}^{-2}$  is the actual temperature.

$$\text{c) } PV = nRT \quad P = 2.1 \times 10^4 \text{ Pa} \quad T = 360 \text{ K}$$

$$n_1 = \frac{PV}{RT} = \frac{2.1 \times 10^4 V}{360 R} \quad n_1 = 700V / 12R$$

$$P = 3 \times 10^3 \text{ Pa} \quad T = 300 \text{ K}$$

$$n_2 = \frac{3 \times 10^3 V}{300 R} = \frac{1000V}{100 R} = \frac{10V}{R}$$

$$PV = nRT \quad n_2 = \frac{PV}{RT}$$

Volume of the vessel (V) remains constant.

R - universal gas constant

$n_1$  - initial no. of water vapour moles

$n_2$  - final no. of water vapour moles

$n_1 - n_2$  = no. of water vapour moles condensed

When the temperature is reduced from 360K to 300K

$\left( \frac{n_1 - n_2}{n_1} \right) \times 100$  ← percentage of condensed water vapour.

$$\left( \frac{\frac{700V}{12R} - \frac{10V}{R}}{\frac{700V}{12R}} \right) \times 100 = \frac{\frac{700}{12} - 10}{\frac{700}{12}} \times 100 = \frac{580}{7} \times 100 = \underline{\underline{83\%}}$$

iv) Relative humidity =  $\frac{\text{Vapour pressure at Room temperature}}{\text{SVP at the room temperature}} \times 100$

$$30\% = P_1 / 2.4 \times 10^3 \quad P_1 = 720 \text{ Pa}$$

$P_1$  = Vapour pressure at  $20^\circ\text{C}$  when  $\text{RH} = 30\%$ .

$$PV = nRT \quad V = 0.5 \text{ m}^3 \quad P = 720 \text{ Pa} \quad R = 8.31 \text{ J mol}^{-1} \text{ K}^{-1} \quad T = 20^\circ\text{C} = 293 \text{ K}$$

$$n_1 = \frac{PV}{RT} = \frac{360}{8.31 \times 293} \text{ moles}$$

$n_1$  - no. of (unsaturated) water vapour moles. unsaturated vapour shows ideal gas behaviour.

$\therefore PV = nRT$  ideal gas equation is applicable.

Mass of water vapour at  $20^\circ\text{C}$  (unsaturated in the atmosphere)  $m_1 = n \times M = \frac{360}{8.31 \times 293} \times 18 \text{ g mol}^{-1}$

$$m_1 = 2.66 \text{ g}$$

unsaturated vapour pressure when the relative humidity increases to 65% -

$$65 = \left( \frac{P_2}{2.4 \times 10^3} \right) \times 100 \quad P_2 = 65 \times 24 \text{ Pa} = 1560 \text{ Pa}$$

$$n_2 = \frac{PV}{RT} = \frac{1560 \times 0.5 \text{ m}^3}{8.31 \times 293 \text{ K}} \quad m_2 = n_2 \times M$$

$$m_2 = \frac{1560 \text{ Pa} \times 0.5 \text{ m}^3}{8.31 \text{ J mol}^{-1} \text{ K}^{-1} \times 293 \text{ K}} \times 18 \text{ g mol}^{-1} = 5.767 \text{ g}$$

mass of water vapour to be added:  $(m_2 - m_1) = 3.11 \text{ g}$  per second

Mass of water vapour added in 1 hour =  $3.11 \text{ g} \times 3600 \text{ s} = \underline{\underline{11.16 \text{ Kg}}}$   
(1 hour = 3600 s)



- 10) A) i) 02    ii) a) 01    b) 01    iii) a) 02    b) 01  
 c) 02 + 02    iv) 04

9) A) a) i)  $E = V + Ir$      $V = 120V$      $r = 1\Omega$      $I = 0.5A$   
 $E = 120 + (0.5 \times 1) = \underline{\underline{120.5V}}$

ii)  $P = I^2 r = (0.5A)^2 \times 1\Omega = \underline{\underline{0.25W}}$

iii) Power output of the source (battery) =  $EI$   
 $P = EI = 120.5V \times 0.5A = \underline{\underline{60.25W}}$

iv) Power delivered to the set of bulbs by the source = Power output of the source - Power wasted in the source in the form of heat  
 $= 60.25W - 0.25W = \underline{\underline{60W}}$

v)  $P = V^2/R$      $R = V^2/P = \frac{120V \times 120V}{60W} = 240\Omega$   
 $V = 120V$  : terminal potential supply to the bulbs  
 $P = 60W$  : power supply to the network of bulbs

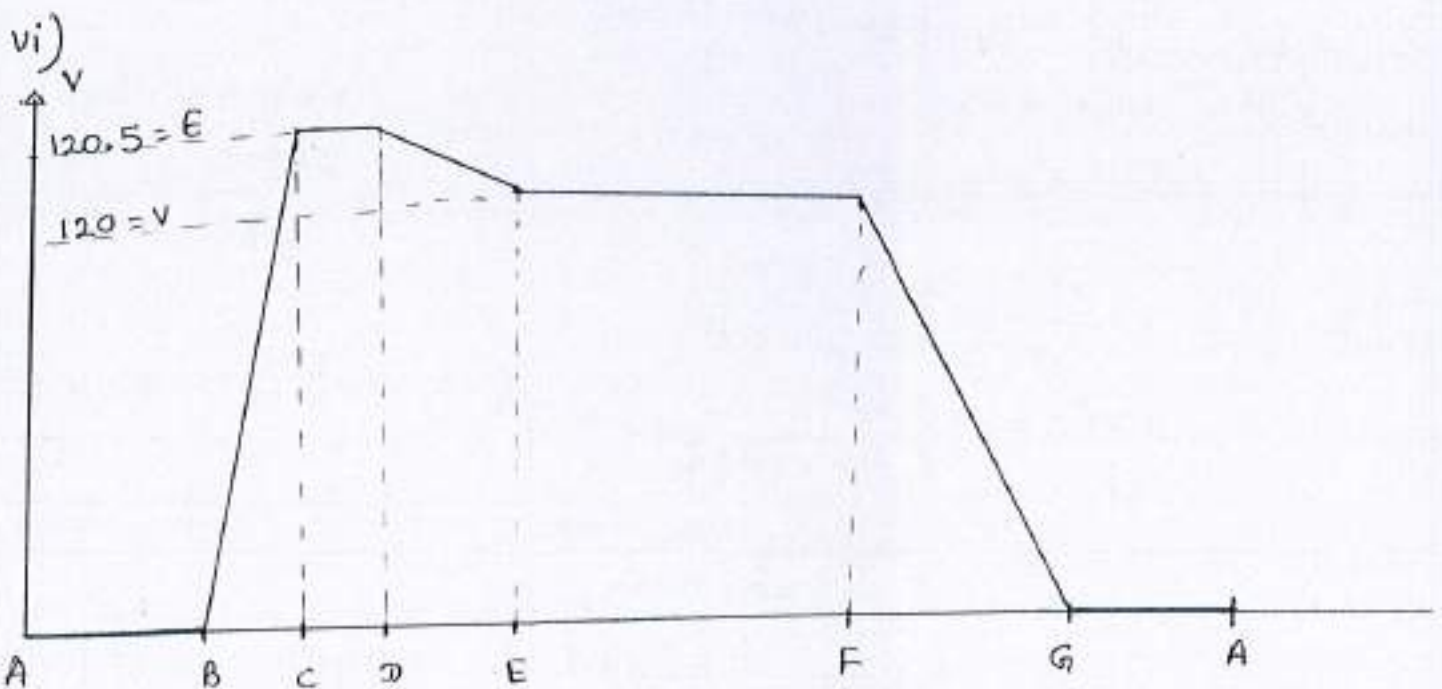

b) i) When one of the bulbs goes out of order (burnt or not functioning) the entire set of bulbs doesn't light.

$$ii) P = \frac{V^2}{R_{eq}} \quad P = 60W \quad R_{eq} = 6R \quad V = 120V$$

Let  $R$  be the resistance of one bulb.  
 $P$  - Power delivered to the set of bulbs by the source  $\times$   
 $V$  - terminal potential supply of  $X$  to the bulbs.  
 hence the 6 bulbs are in series: equivalent resistance =  $6R$

$$P = \frac{V^2}{6R} \quad R = \frac{V^2}{6P} = \frac{120 \times 120}{6 \times 60} = 40 \Omega$$

Power of the bulb across 120V <sup>terminal potential supply:</sup>

$$P = \frac{V^2}{R} = \frac{120 \times 120}{40} = 360W$$

Current flow through the bulb:  $P = VI \quad I = P/V$   
 $I = 120V / 40V = 3A$

iii) When the bulbs are connected in parallel 120V terminal potential supply applies at each bulb.  
 $\therefore P = V^2/R = \frac{120 \times 120}{40} = 360W$  ← Power consumption of each bulb

total power consumption for the 6 bulbs:  $360 \times 6 = 2160W$

**OR** equivalent resistance of the circuit:  $R/6 = 40/6 \Omega$

$$V = IR \quad I = V/R = \frac{120}{40/6} = \frac{120 \times 6}{40} A = 18A$$

Current through the circuit increases to 18A  
 high power consumption (wires with wider cross sectional - diameter are needed to be connected in the circuit.)

iv) As the broken bulb does not respond i.e. it is with infinite internal resistance: the total e.m.f. is applied across the  $(V)$ .  $\therefore (V)$  reading = 120.5V



When the ideal (V) connected across the functioning bulb: no potential difference applied across the (V) b'cos current flows through the functioning bulb. no current flows through the ideal (V) due to its' very high (infinite) resistance.  $\therefore$  (V) reads zero when connected across a functioning bulb.

- 9) A) a) i) 02    ii) 01    iii) 02    iv) 01    v) 01    vi) 02  
 b) i) 01    ii) 02    iii) 01    iv) 02

8) i)  charges distribute either side of the conducting plate.

ii) decreases. Potential of the charged plate is the work to be performed from external in bringing a charge to the plate. An earthed plate which is at zero potential decreases the potential of the charged plate. (01)

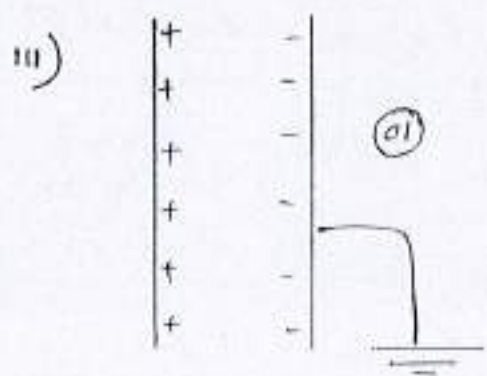

iv) A dielectric material in between the plates reduces the potential difference between the plates. (01)

v) a)  $W = VQ = EQ$  (01)  
 Energy supplied by the cell

b) energy stored in the capacitor =  $\frac{1}{2} EQ$  (01)

vi) The upper plate shifts down by extending the springs due to the electrostatic attraction between the top and bottom plates (due to the electric charges on the plates.) (01)

$$b) F = Eq$$

$$E = V/d$$

$$\frac{(V+0)}{2} \times \frac{1}{d}$$

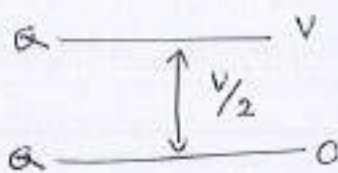

$$E = \frac{V}{2d}$$

$$F = \frac{VQ}{2d}$$

$$F = \frac{VQ}{2d} \quad (1)$$

$$c) F = ke$$

$$F = \frac{VQ}{2d}$$

$$F = 4F'$$

$F'$  = extension force by each spring

$$\frac{VQ}{2d} \times \frac{1}{4} = ke \quad (1)$$

$$F' = ke$$

$e$  - extension of one spring  
 $k$  - spring constant

$$e = \frac{VQ}{8kd}$$

$$Q = CV$$

$$C = \frac{A\epsilon_0}{d}$$

$$Q = \frac{A\epsilon_0}{d} V$$

$$e = V \times \frac{A\epsilon_0 V}{d} \times \frac{1}{8kd}$$

$$e = \frac{A\epsilon_0 V^2}{8kd^2} \quad (1)$$

$$vii) C = 100 \times 10^{-9} F = 10^{-7} F$$

$$A = 100 \times 10^{-4} m^2 = 10^{-2} m^2$$

$$a) Q = CV = 10^{-7} \times 50 V = 5 \times 10^{-6} C$$

$$Q = 5 \mu C \quad (1)$$

$$b) E = \frac{Q}{\epsilon_0 A} \quad (1) \rightarrow E = \frac{Q}{5\epsilon_0 A} = \frac{5 \times 10^{-6} C}{5 \times 9 \times 10^{-12} \times 10^{-2} m^2}$$

$$E = 1.11 \times 10^7 NC^{-1} \quad (1)$$

$$\epsilon_0 = 9 \times 10^{-12} Fm^{-1}$$

c)



$$Q - q = \frac{Q}{k}$$

$$q = Q \left(1 - \frac{1}{k}\right)$$

$$= 5 \times 10^{-6} \left(1 - \frac{1}{5}\right)$$

$$= 5 \times 10^{-6} \times \frac{4}{5}$$

$$= 4 \times 10^{-6} C \quad (1)$$

$$\frac{Q - q}{\epsilon_0 A} = \frac{Q}{k\epsilon_0 A} = E \quad (1)$$